



**BURNER**

WWW.BURNERFIRE.COM

337-237-4547



# SKID UNIT CATALOG



# **DRY CHEMICAL SKID UNITS**

## **DESCRIPTION**

Burner Dry Chemical Skid Units are designed and constructed for one-person operation. Chemical and pressure is sealed in the agent cylinder and is protected from moisture and contamination. The advanced expulsion system allows each hose reel to obtain chemical through independent discharge tubes affording a constant discharge rate on demand. A plurality of discharge tubes individually controlled allows for optional installations and isolated discharges when needed. With individual manually controlled discharge valves, either hose reel can be actuated without charging the hose reel not in use. Hose reels located in remote locations can be actuated independent of other remote reels and the remaining reels on the skid unit. All Units can accommodate manual operation or configured for automatic discharge. Units can be optionally completed with standard skid, piped installation or trailer mount.

## **APPLICATION**

Burner Dry Chemical Skid Units provide large capacity fire fighting capabilities for extinguishment for Class B and C hazards. Common high hazard risk areas include:

- LNG Transport Vessels and Facilities
- Cargo Areas and Loading Stations
- Oil and Gas Production Facilities
- Aircraft Rescue and Hangar Facilities
- Fuel Storage Locations
- Marine Port Operations
- Floating Production Storage Units
- Chemical, Textile, Plastics Manufacturing
- Paint and Solvent Areas
- Transformers

## **COMPONENTS**

Burner Dry Chemical Skid Units are self-contained consisting of a carbon steel agent tank assembly designed and constructed in accordance to the latest ASME Section VIII, Div. 1 unfired pressure vessel code. Agent tank is equipped with powder fluffing tube and mechanical pressure safety valve. The carrier and expellant agent shall be nitrogen and cylinders shall be of DOT or ISO standard. Nitrogen cylinder storage racks are an integrated part of the skid and mounted in horizontal position. Nitrogen cylinders are secured with welded clamps. Nitrogen cylinders are removable from the operating position of the unit adjacent to mounted controls. Complete units are constructed with materials suitable for marine environments. Components are broken down to individual units prior to application of the corrosion resistant paint finish to ensure all surfaces receive the maximum protection possible. Systems are assembled with corrosion resistant hardware and fittings. Skid Welding shall be in accordance with AWS D.1.1 Structural Welding Code, Latest Edition. Optional guards shall be installed on request to protect the Units in areas affected by heat radiation or other operational or environmental hazards.





**BURNER**

[WWW.BURNERFIRE.COM](http://WWW.BURNERFIRE.COM)

337-2374547

# DRY CHEMICAL UNITS



# 350 POUND DRY CHEMICAL UNIT



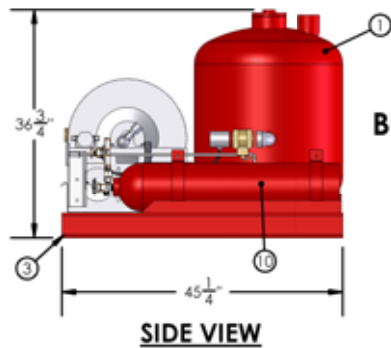
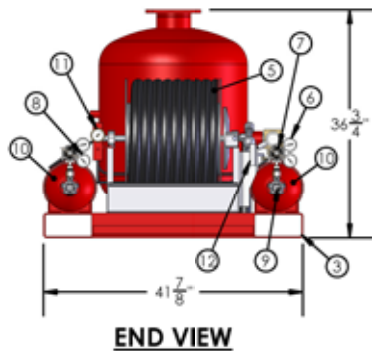
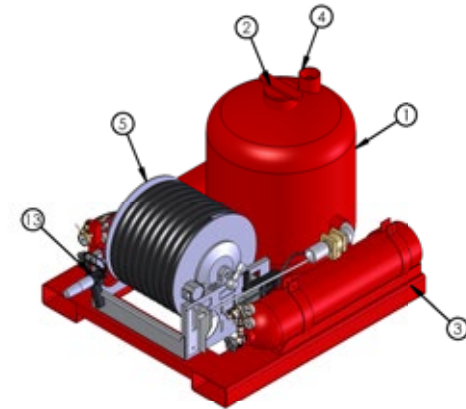
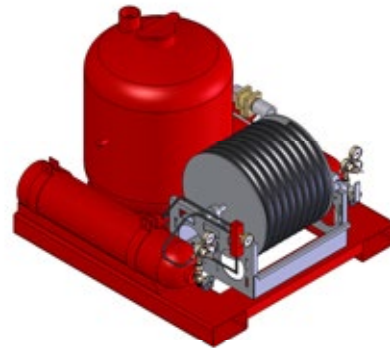
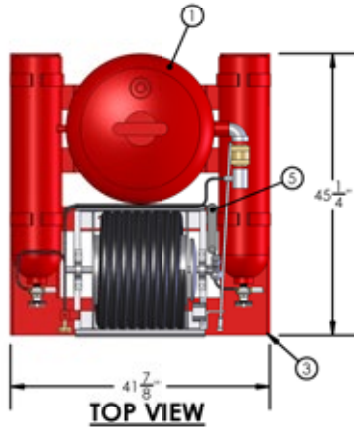

**350 lb DRY CHEMICAL UNIT  
BURNER MODEL AF-DC-350-1HR**

Empty Weight - 552 lbs.

Full Weight - 902 lbs.

ITEM NO.	UNIT DESCRIPTION
1	A.S.M.E. CODE CYLINDER
2	4" FILL CAP
3	SKID ASSEMBLY
4	250 POP-OFF
5	HOSE REEL MANUAL REWIND W/ 100FT 1" HOSE
6	REGULATOR PRESSURE GAUGE
7	NITROGEN REGULATOR
8	HIGH PRESSURE GAUGE
9	NITROGEN CYLINDER VALVE
10	NITROGEN CYLINDER
11	EXTINGUISHER PRESSURE GAUGE
12	MANUAL CONTROL VALVE
13	SHUT OFF

# 500 POUND DRY CHEMICAL UNIT



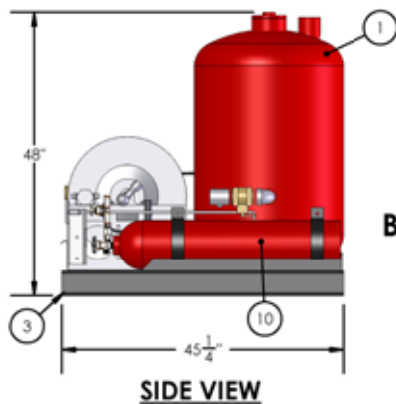
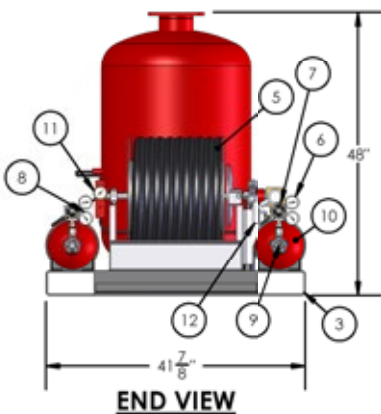
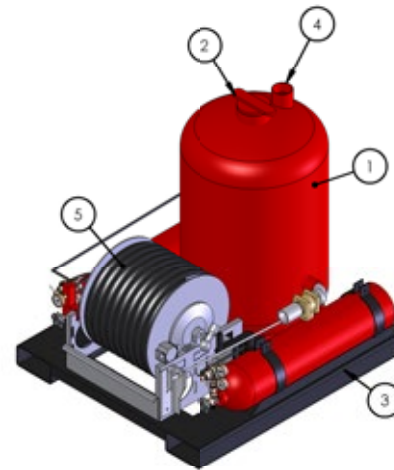
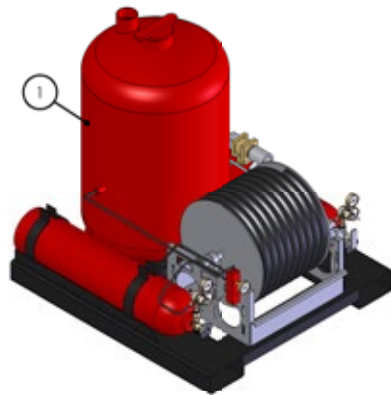
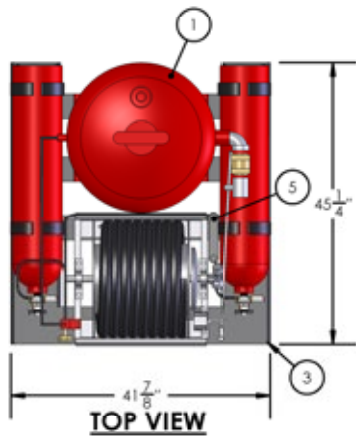

**500 lbs DRY CHEMICAL UNIT  
BURNER MODEL AF-DC-500-1HR**

Empty Weight - 800 lbs.

Full Weight - 1,300lbs.

ITEM No.	UNIT DESCRIPTION
1	24" A.S.M.E. CODE CYLINDER
2	4" FILL CAP
3	2-110 CF EXPELLANT BOTTLESSKID ASSEMBLY
4	250 POP-OFF
5	HOSE REEL MANUAL REWIND W/ 100FT 1" HOSE
6	REGULATOR PRESSURE GAUGE
7	NITROGEN REGULATOR
8	HIGH PRESSURE GAUGE
9	NITROGEN CYLINDER VALVE
10	NITROGEN CYLINDER
11	EXTINGUISHER PRESSURE GAUGE
12	MAUAL CONTROL VALVE
13	SHUT OFF

# 1000 POUND DRY CHEMICAL UNIT

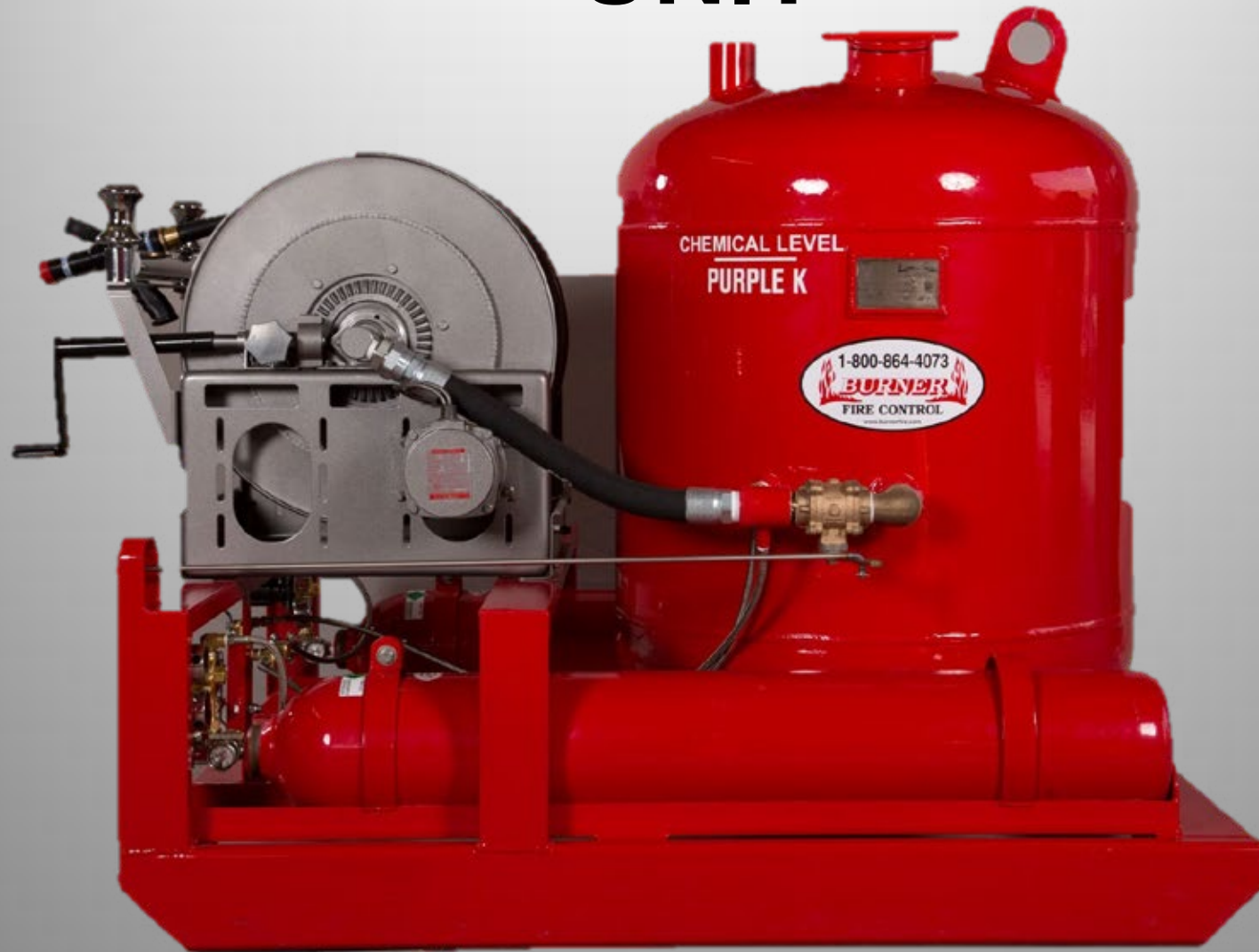

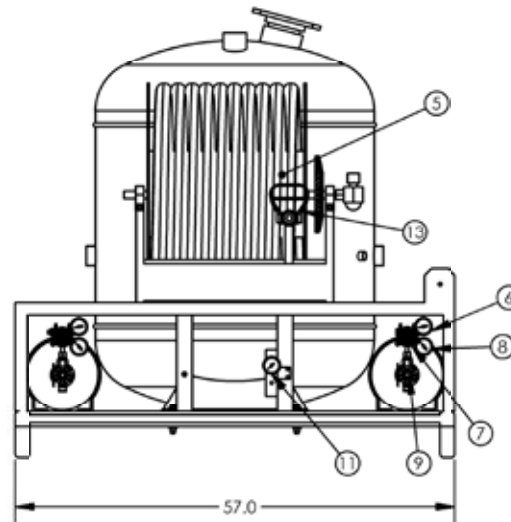
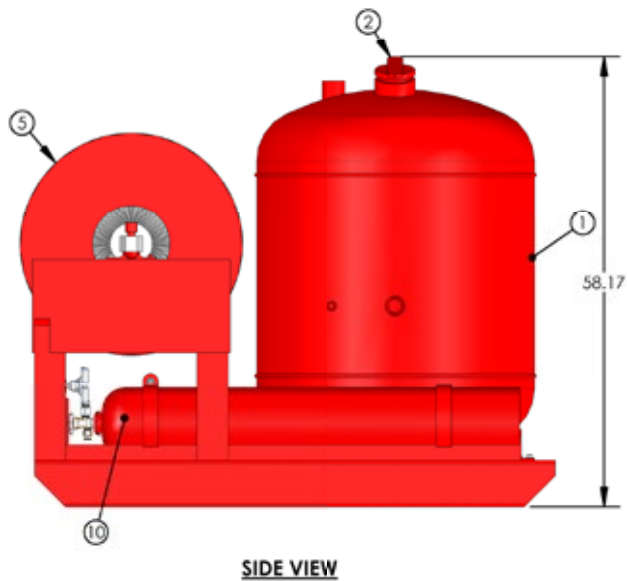
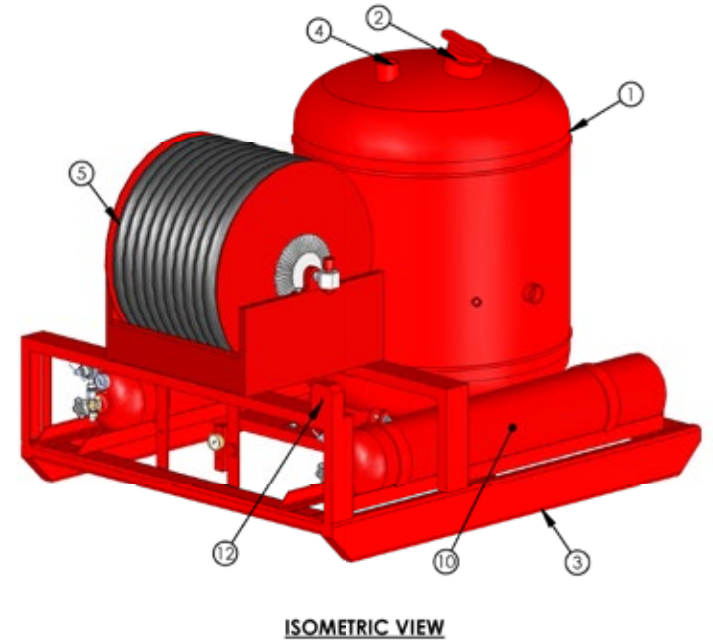
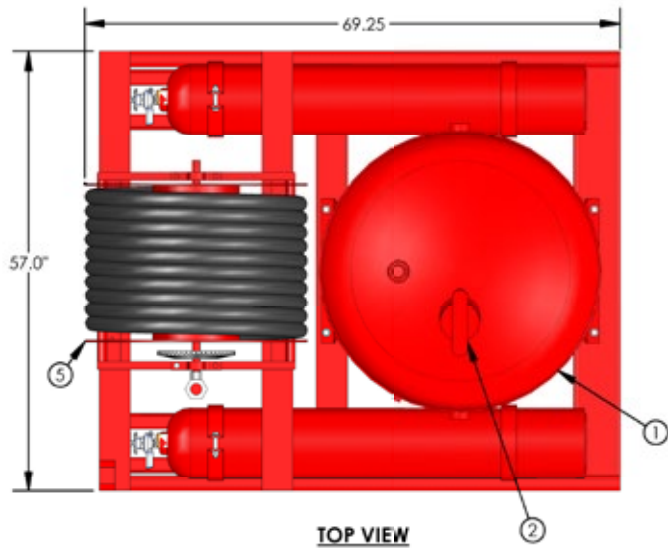

**1000 lb DRY CHEMICAL UNIT  
BURNER MODEL AF-DC-1000-1HR**

Empty Weight - 2,000 lbs.

Full Weight - 3,000 lbs.

ITEM NO.	UNIT DESCRIPTION
1	A.S.M.E. CODE CYLINDER
2	4" FILLER CAP
3	SKID ASSEMBLY
4	250 POP-OFF
5	HOSE REEL MANUAL REWIND W/ 100 FT 1" HOSE
6	REGULATOR PRESSURE GAUGE
7	NITROGEN REGULATOR
8	HIGH PRESSURE GAUGE
9	NITROGEN CYLINDER VALVE
10	NITROGEN CYLINDER
11	EXTINGUISHER PRESSURE GAUGE
12	MANUAL CONTROL VALVE
13	SHUT OFF

# 1500 POUND DRY CHEMICAL UNIT

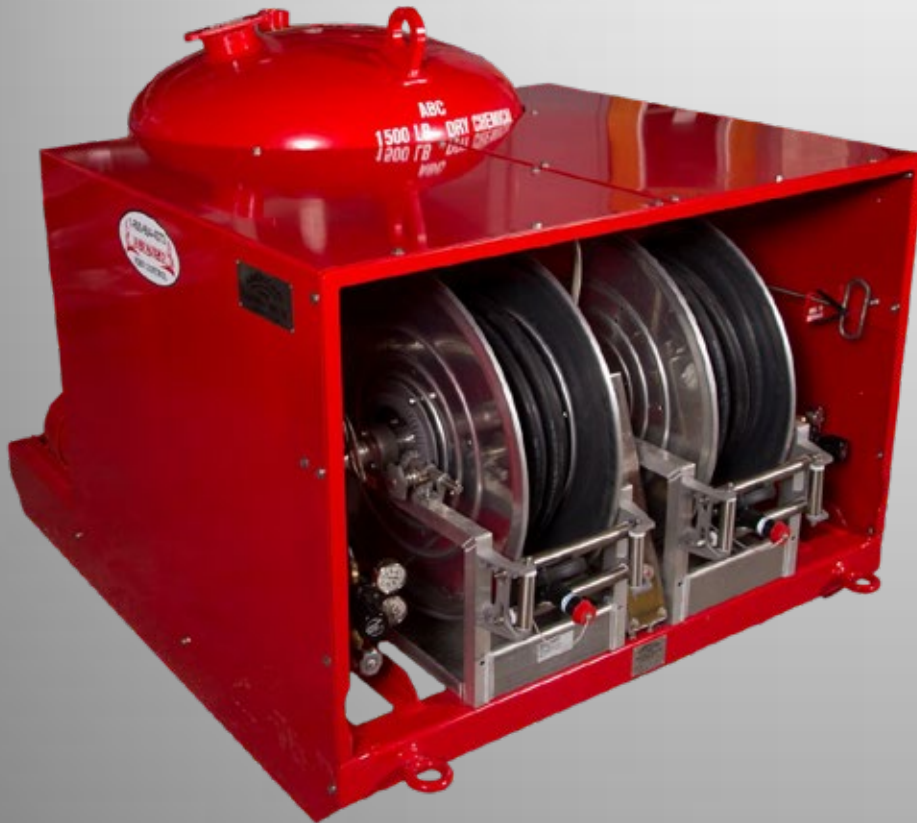

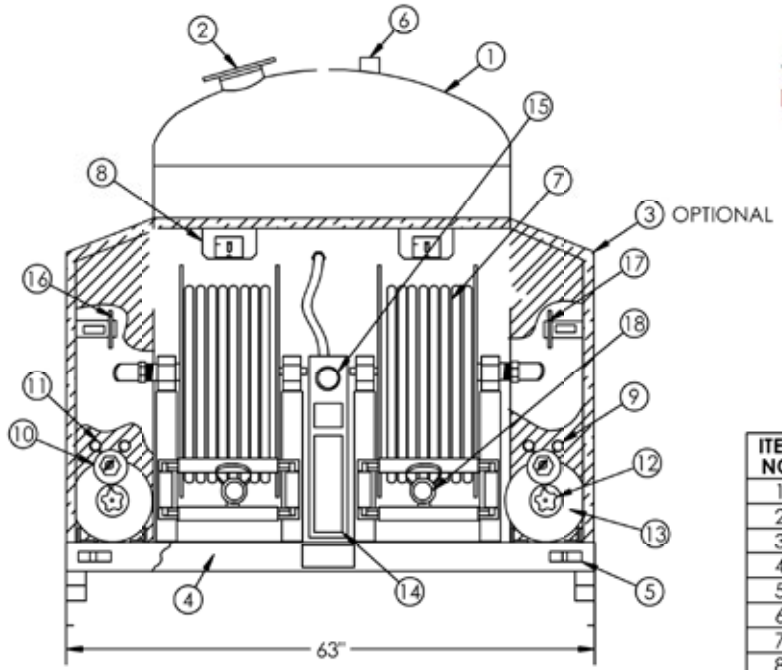
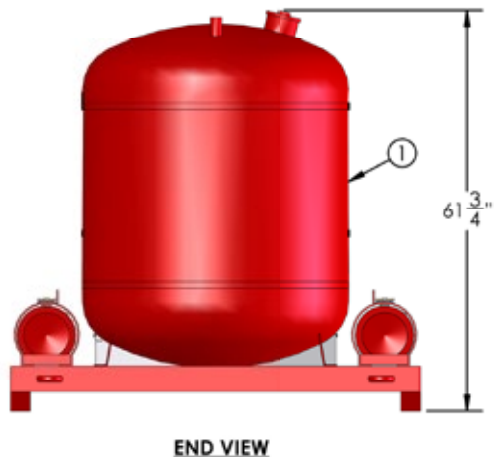
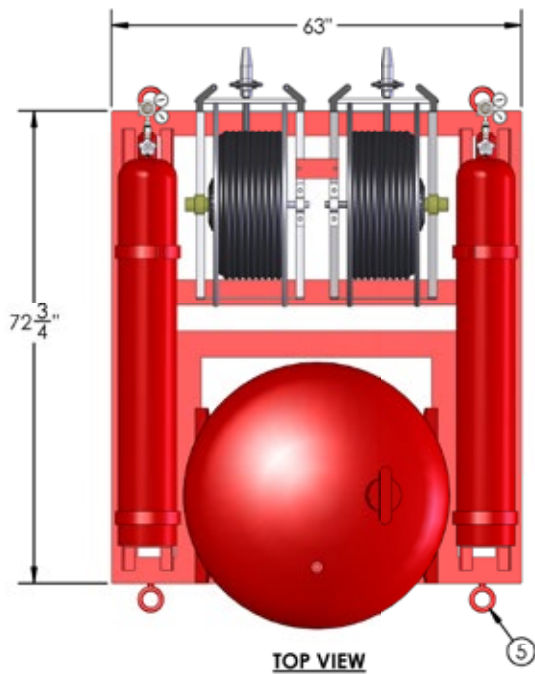

**1500 LB DRY CHEMICAL UNIT**  
**BURNER MODEL AF-DC-1500-2HR**

EMPTY WEIGHT - 2,556  
 FULL WEIGHT - 4,056

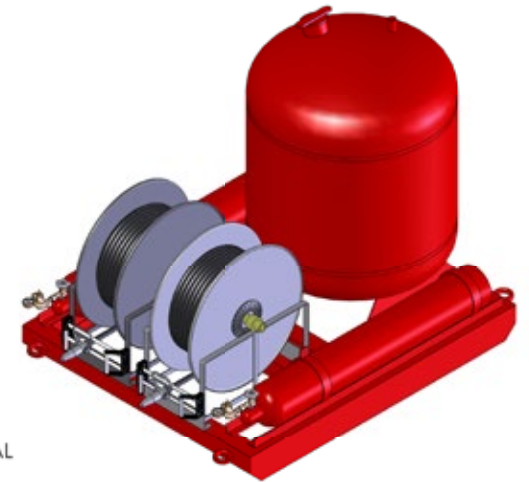

**ISOMETRIC VIEW**

ITEM NO.	UNIT DESCRIPTION
1	A.S.M.E. CODE CYLINDER
2	4" FILLER CAP
3	REMOVABLE COWLING - OPTIONAL
4	SKID ASSEMBLY
5	TIE DOWN EYELET
6	250 POP-OFF
7	HOSE REEL MANUAL REWIND W/ 100FT 1" HOSE
8	REMOTE BLEED VALVE
9	REGULATOR PRESSURE GAUGE
10	NITROGEN REGULATOR
11	HIGH PRESSURE GAUGE
12	NITROGEN CYLINDER VALVE
13	NITROGEN CYLINDER
14	CONTROL CONSOLE
15	EXTINGUISHER PRESSURE GAUGE
16	MANUAL CONTROL VALVE-LEFT HOSE REEL
17	MANUAL CONTROL VALVE-RIGHT HOSE REEL
18	SHUT OFF

# 2000 POUND DRY CHEMICAL UNIT



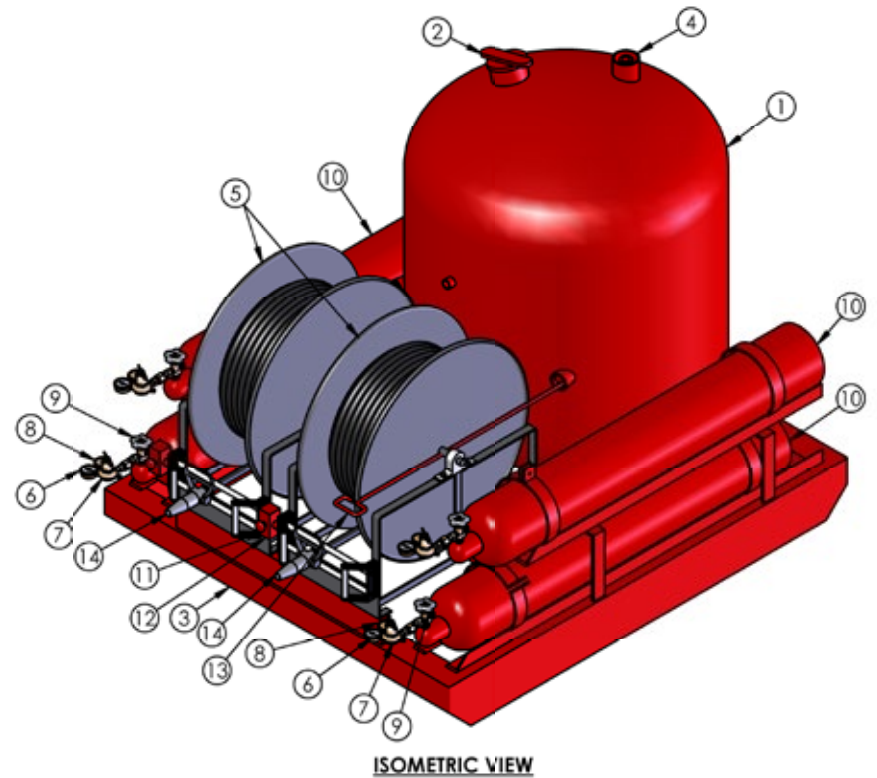
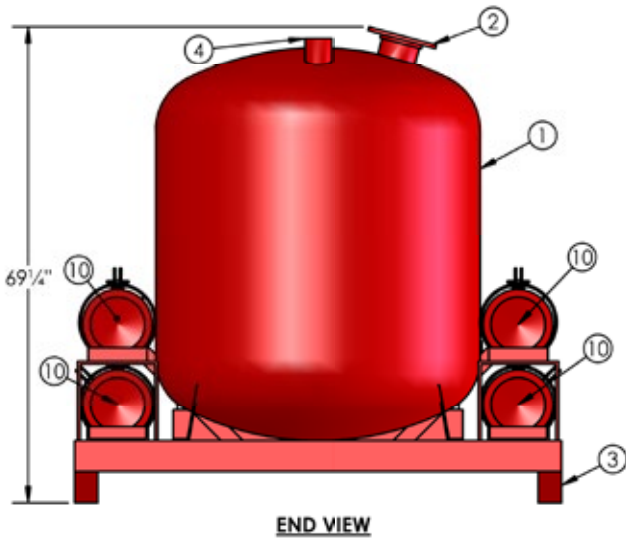
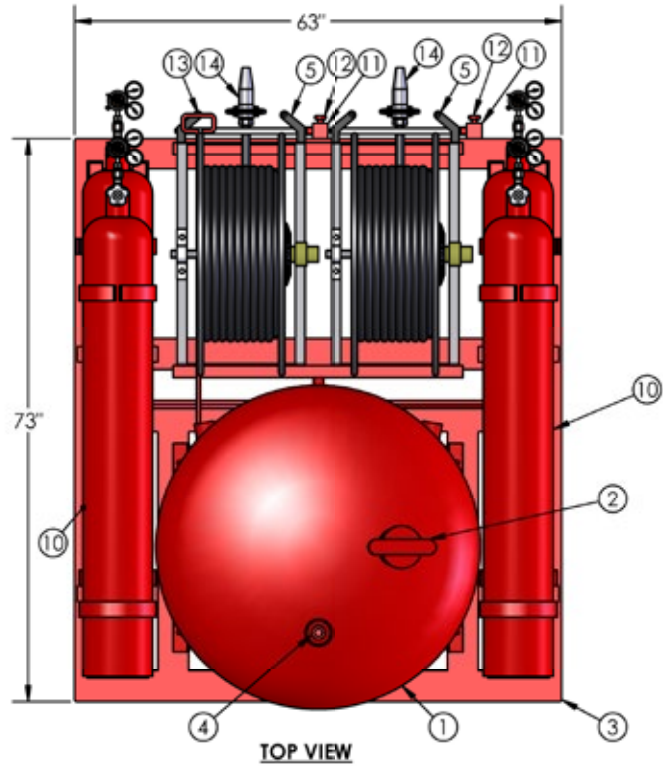

**2000 LB DRY CHEMICAL UNIT**  
**BURNER MODEL AF-DC-2000-2HR**

EMPTY WEIGHT - 3,000 lbs

FULL WEIGHT - 5,000 lbs

ITEM NO.	UNIT DESCRIPTION
1	A.S.M.E. CODE CYLINDER - 42" O.D.
2	4" FILLER CAP
3	SKID ASSEMBLY
4	250 POP-OFF
5	HOSE REEL MANUAL REWIND W/ 100FT 1" HOSE
6	REGULATOR PRESSURE GAUGE
7	NITROGEN REGULATOR
8	HIGH PRESSURE GAUGE
9	NITROGEN CYLINDER VALVE
10	NITROGEN CYLINDER
11	NITROGEN MANIFOLD
12	EXTINGUISHER PRESSURE GAUGE
13	MANUAL CONTROL VALVE HOSE REEL
14	SHUT OFF

# 2500 POUND DRY CHEMICAL UNIT



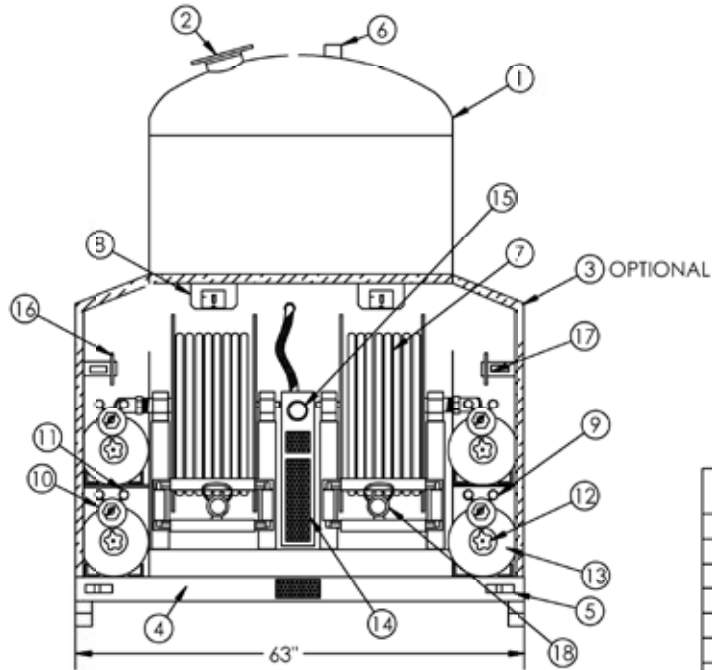
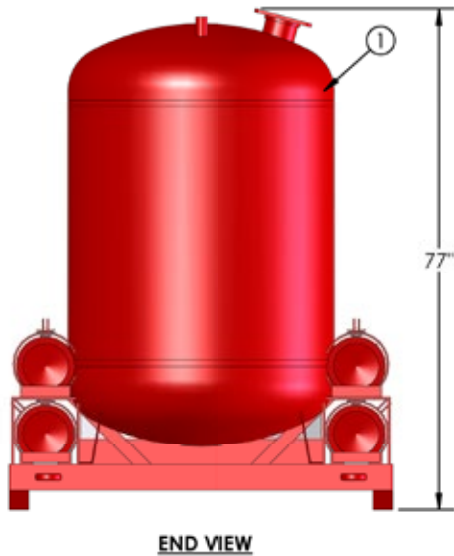
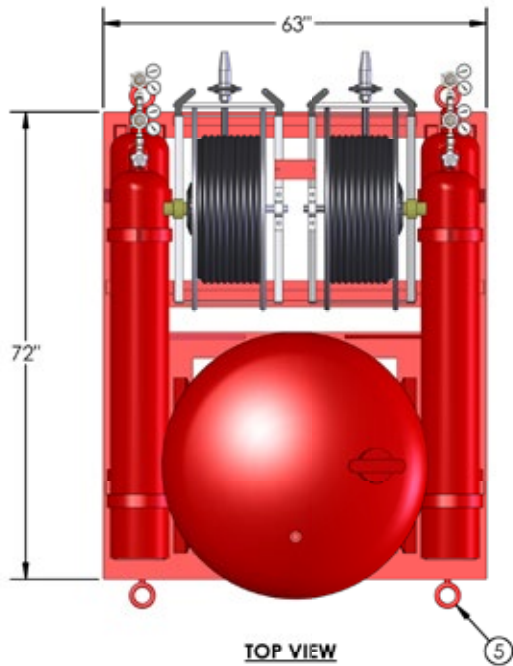

**2500 LB DRY CHEMICAL UNIT**  
**BURNER MODEL AF-DC-2500-2HR**

EMPTY WEIGHT - 3,250 lbs

FULL WEIGHT - 5,750 lbs

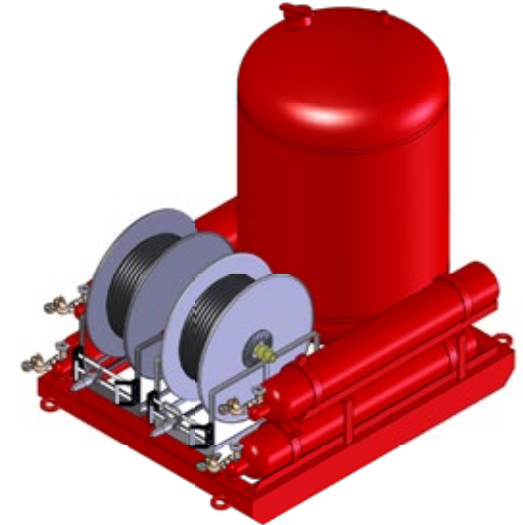

**ISOMETRIC VIEW**

ITEM NO.	UNIT DESCRIPTION
1	A.S.M.E. CODE CYLINDER
2	4" FILLER CAP
3	REMOVABLE COWLING - OPTIONAL
4	SKID ASSEMBLY
5	TIE DOWN EYELET
6	250 POP-OFF
7	HOSE REEL MANUAL REWIND W/ 100FT 1" HOSE
8	REMOTE BLEED VALVE
9	REGULATOR PRESSURE GAUGE
10	NITROGEN REGULATOR
11	HIGH PRESSURE GAUGE
12	NITROGEN CYLINDER VALVE
13	NITROGEN CYLINDER
14	CONTROL CONSOLE
15	EXTINGUISHER PRESSURE GAUGE
16	MANUAL CONTROL VALVE-LEFT HOSE REEL
17	MANUAL CONTROL VALVE-RIGHT HOSE REEL
18	SHUT OFF

# 3000 POUND DRY CHEMICAL UNIT



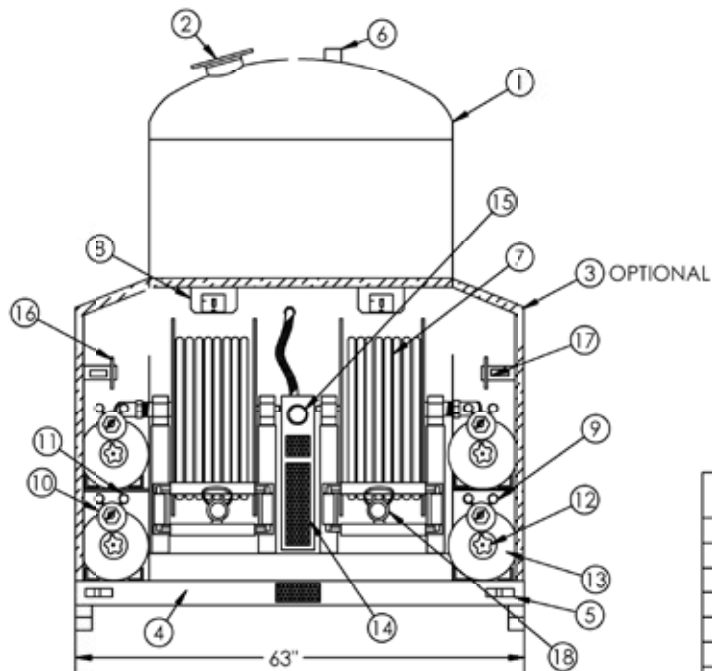
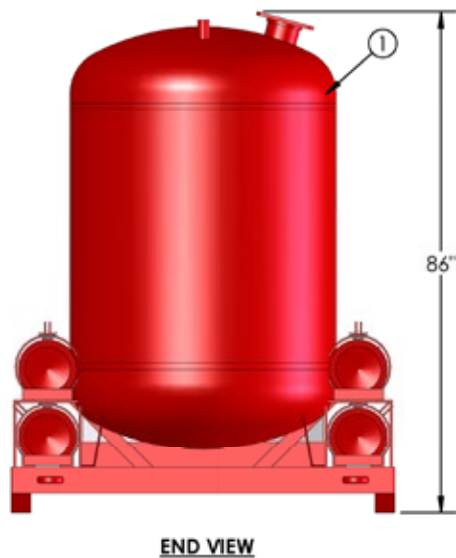
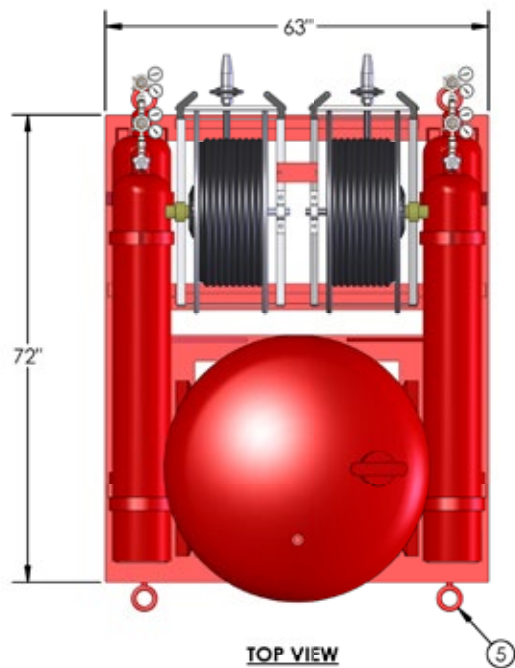

**3000 LB DRY CHEMICAL UNIT**  
**BURNER MODEL AF-DC-3000-2HR**

EMPTY WEIGHT - 3,375 lbs

FULL WEIGHT - 6,375 lbs

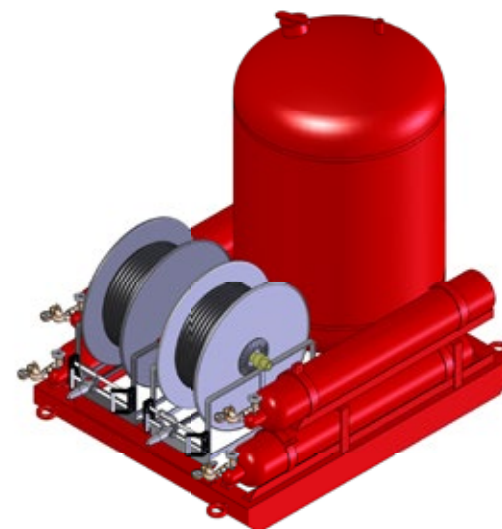

**ISOMETRIC VIEW**

ITEM NO.	UNIT DESCRIPTION
1	A.S.M.E. CODE CYLINDER
2	4" FILLER CAP
3	REMOVABLE COWLING - OPTIONAL
4	SKID ASSEMBLY
5	TIE DOWN EYELET
6	250 POP-OFF
7	HOSE REEL MANUAL REWIND W/ 100FT 1" HOSE
8	REMOTE BLEED VALVE
9	REGULATOR PRESSURE GAUGE
10	NITROGEN REGULATOR
11	HIGH PRESSURE GAUGE
12	NITROGEN CYLINDER VALVE
13	NITROGEN CYLINDER
14	CONTROL CONSOLE
15	EXTINGUISHER PRESSURE GAUGE
16	MANUAL CONTROL VALVE-LEFT HOSE REEL
17	MANUAL CONTROL VALVE-RIGHT HOSE REEL
18	SHUT OFF



# **TWIN AGENT SKID UNITS**

## **DESCRIPTION**

Burner Twin Agent Skid Units provide dual agent mitigation using dry chemical with the added fire response properties of an integrated foam unit proven to be one of the most effective tools in mitigating extreme risk areas with multiple hazards. Units are designed and constructed for one-person operation. . Units can accommodate manual operation or configured for automatic discharge. Units can be optionally completed with standard skid or trailer mount.

## **APPLICATION**

Burner Twin Agent Skid Units provide large capacity fire fighting capabilities for extinguishment for Class A, B, and C hazards. Common high hazard risk areas include:

- Flammable Liquid Storage and Transport
- Marine Port Operations
- Petrochemical Plants
- Mining Operations
- Aircraft Rescue and Hangar Facilities
- Heliports and Helidecks
- Industrial and Municipal Fire Brigades
- Military Fire Teams
- Oil and Gas Production Facilities
- LNG Bunkering Stations

## **COMPONENTS**

Burner Twin Agent Skid Units are self-contained consisting of dual carbon steel agent tank assemblies designed and constructed in accordance to the latest ASME Section VIII, Div. 1 unfired pressure vessel code. Agent tanks are equipped with mechanical pressure safety valves. Dry Chemical tank will be charged with Purple-K potassium bicarbonate. Foam tank shall be internally lined with an epoxy finish and will accommodate pre-mixed foam or CAFS. The carrier and expellant agent shall be nitrogen and cylinders shall be of DOT or ISO standard. Nitrogen cylinder storage racks are an integrated part of the skid and mounted in horizontal position. Nitrogen cylinders are secured with welded clamps. Nitrogen cylinders are removable from the operating position of the unit adjacent to mounted controls. . Complete units are constructed with materials suitable for marine environments. Components are broken down to individual units prior to application of the corrosion resistant paint finish to ensure all surfaces receive the maximum protection possible. Systems are assembled with corrosion resistant hardware and fittings. Skid Welding shall be in accordance with AWS D.1.1 Structural Welding Code, Latest Edition.





**BURNER**

[WWW.BURNERFIRE.COM](http://WWW.BURNERFIRE.COM)

337-237-4547

# TWIN AGENT UNITS



# 200 POUND DRY CHEMICAL 80 GALLON AFFF TWIN AGENT UNIT





**BURNER**

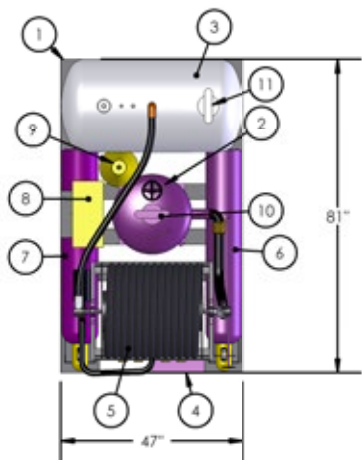

**TOP VIEW**

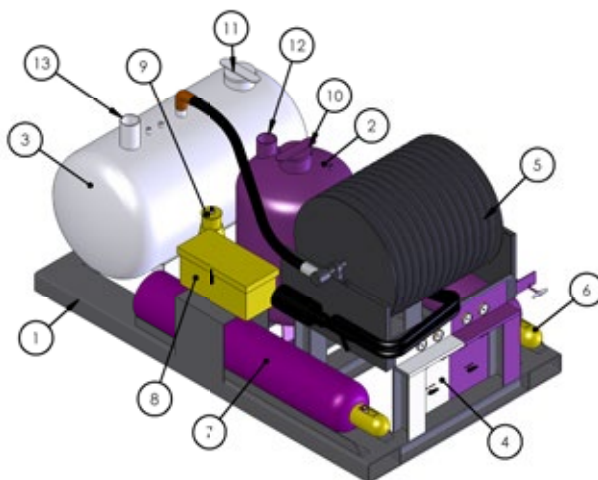

**ISOMETRIC VIEW**

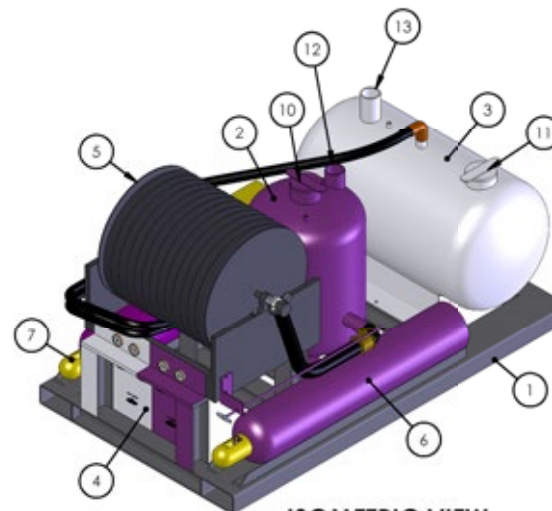

**ISOMETRIC VIEW**

**TWIN AGENT UNIT 200 DC 80 AFFF**

**BURNER MODEL AF-200-DC/AFFF-80-1HR**

Empty Weight - 1,364 lbs.

Full Weight - 2,230 lbs.

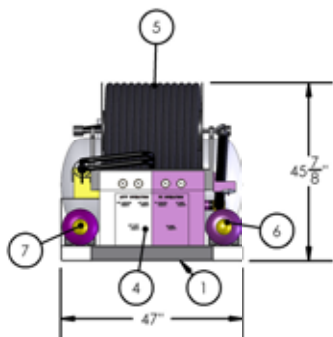

**END VIEW**

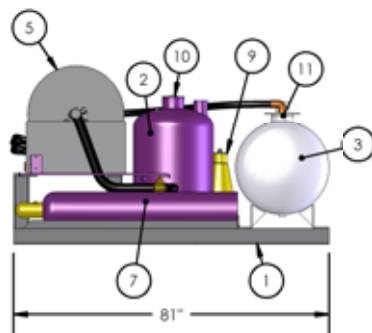

**SIDE VIEW**

ITEM No.	UNIT DESCRIPTION
1	ALUMINUM SKID W/ COMMERCIAL FORKLIFT CAPABILITIES
2	200 LBS DRY CHEMICAL TANK
3	80 GALLON AFFF TANK
4	CONTROL PANEL
5	HOSE REEL W/ 100 FT. TWIN 1" HOSES & SHUT OFF
6	220 CF DC EXPELLANT BOTTLE
7	220 CF AFFF EXPELLANT BOTTLE
8	TOOL BOX
9	FUNNEL
10	FILL CAP - DRY CHEMICAL
11	FILL CAP - AFFF
12	250 PSI POP OFF - DRY CHEMICAL
13	250 PSI POP OFF - AFFF

# 450 DRY CHEMICAL 100 AFFF TWIN AGENT UNIT



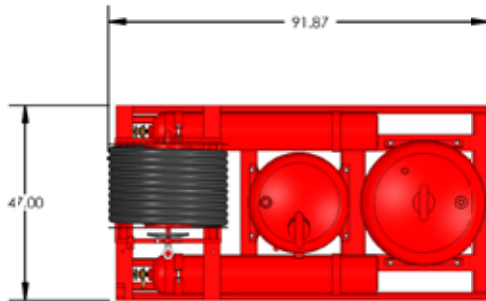

**TOP VIEW**

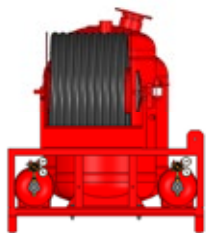

**END VIEW**

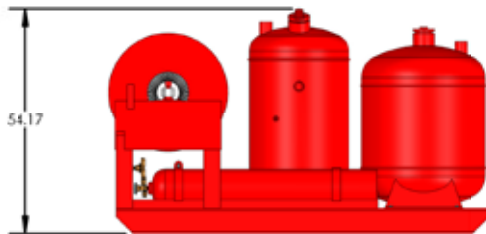

**SIDE VIEW**

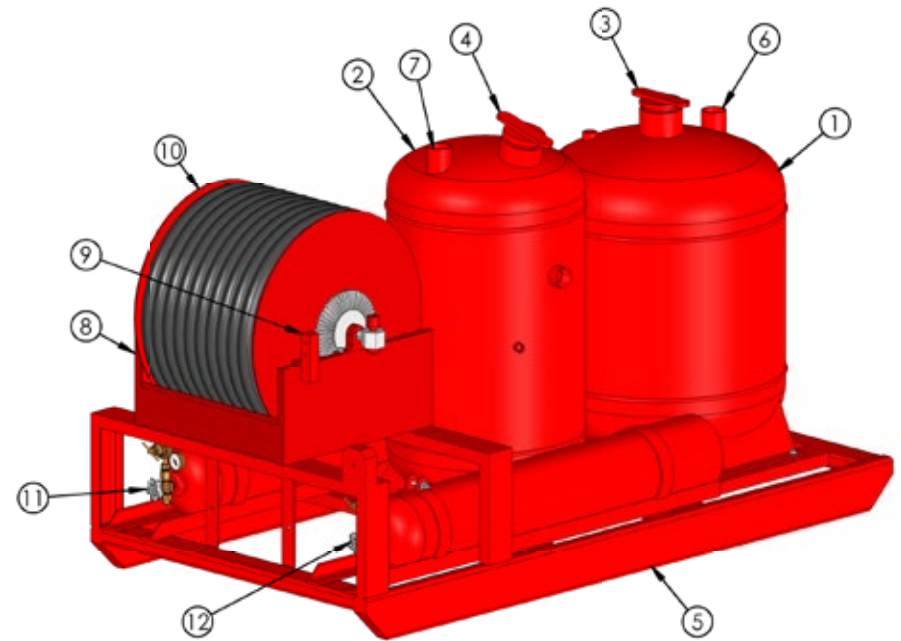

**ISOMETRIC VIEW**

**TWIN AGENT 450 DC 100 AFFF**

**BURNER MODEL AF-450-DC/AFFF-100-1HR**

Empty Weight - 1,995 lbs.

Full Weight - 3,520 lbs.

ITEM No.	UNIT DESCRIPTION
1	100 GALLON ASME CODE CYLINDER AFFF
2	450 LB ASME CODE CYLINDER DRY CHEMICAL
3	4" FILLER CAP AFFF
4	4" FILLER CAP DRY CHEMICAL
5	SKID ASSEMBLY
6	250 PSI POP-OFF AFFF
7	250 PSI POP-OFF DRY CHEMICAL
8	MANIFOLD AFFF
9	MANIFOLD DRY CHEMICAL
10	HOSE REEL w/ 100 FT, TWIN 1" HOSES & SHUT OFF
11	NITROGEN CYLINDER AFFF
12	NITROGEN CYLINDER DRY CHEMICAL

# 450 POUND PK/150 AFFF TWIN AGENT UNIT

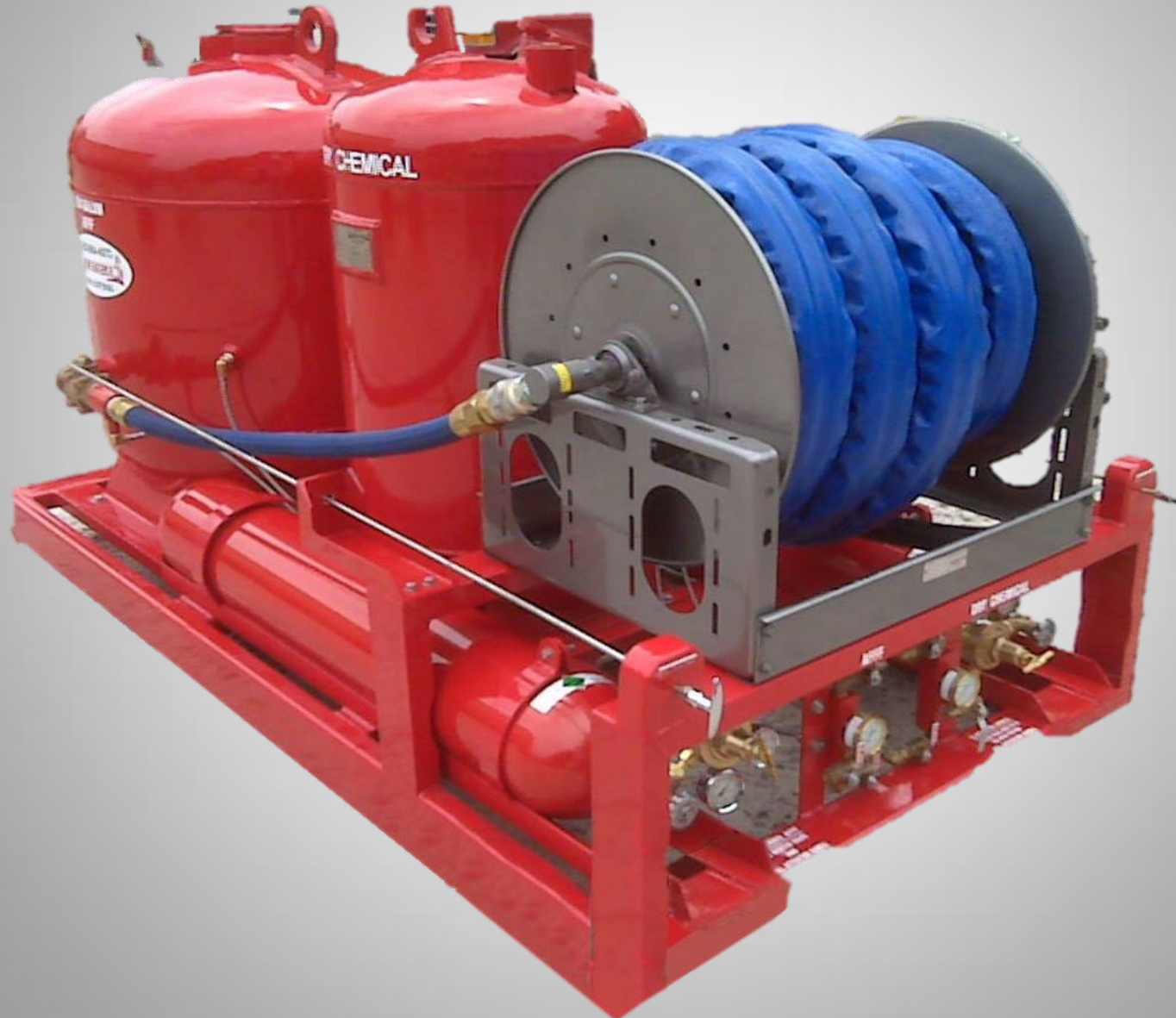

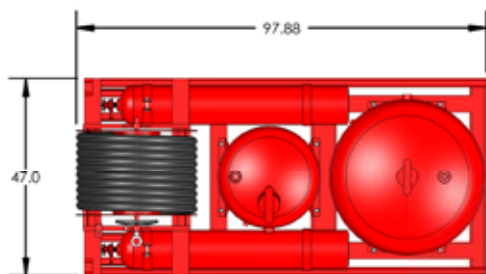

**TOP VIEW**

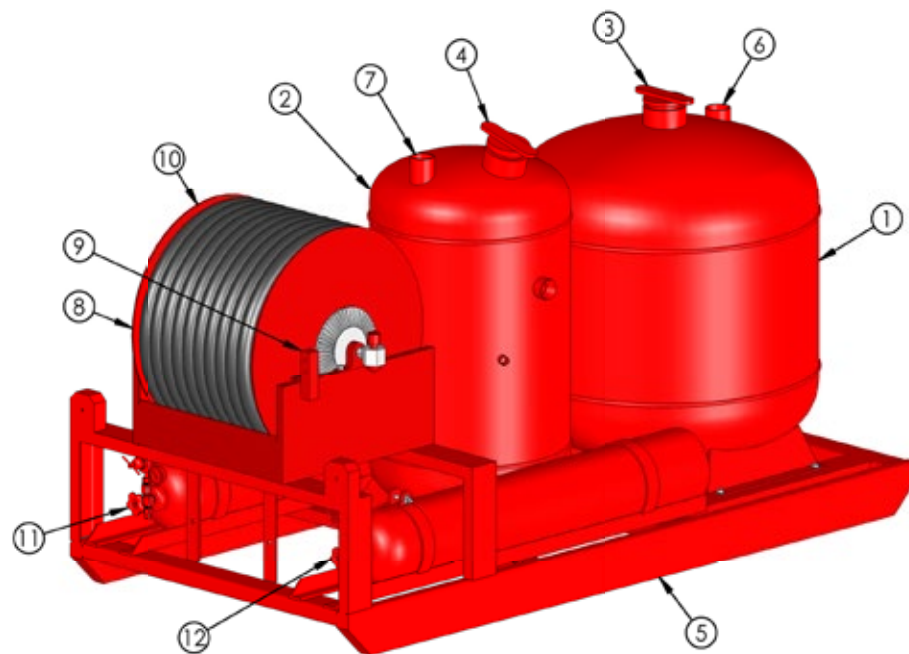

**ISOMETRIC VIEW**

**TWIN AGENT 450 DC 150 AFFF**  
**BURNER MODEL AF-450-DC/AFF-150-1HR**

Empty Weight - 2,420 lbs.

Full Weight - 4,120 lbs.



**END VIEW**

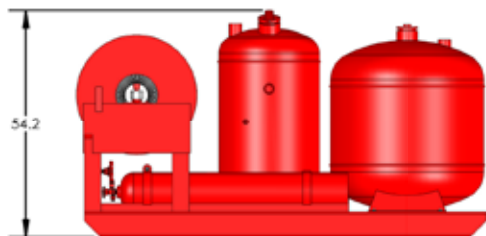

**SIDE VIEW**

ITEM No.	UNIT DESCRIPTION
1	150 GALLON ASME CODE CYLINDER AFFF
2	450 LB ASME CODE CYLINDER DRY CHEMICAL
3	4" FILLER CAP AFFF
4	4" FILLER CAP DRY CHEMICAL
5	SKID ASSEMBLY
6	250 PSI POP-OFF AFFF
7	250 PSI POP-OFF DRY CHEMICAL
8	MANIFOLD AFFF
9	MANIFOLD DRY CHEMICAL
10	HOSE REEL w/ 100 FT. TWIN 1" HOSES & SHUT OFF
11	NITROGEN CYLINDER AFFF
12	NITROGEN CYLINDER DRY CHEMICAL

# 450 POUND PK/200 AFFF TWIN AGENT UNIT

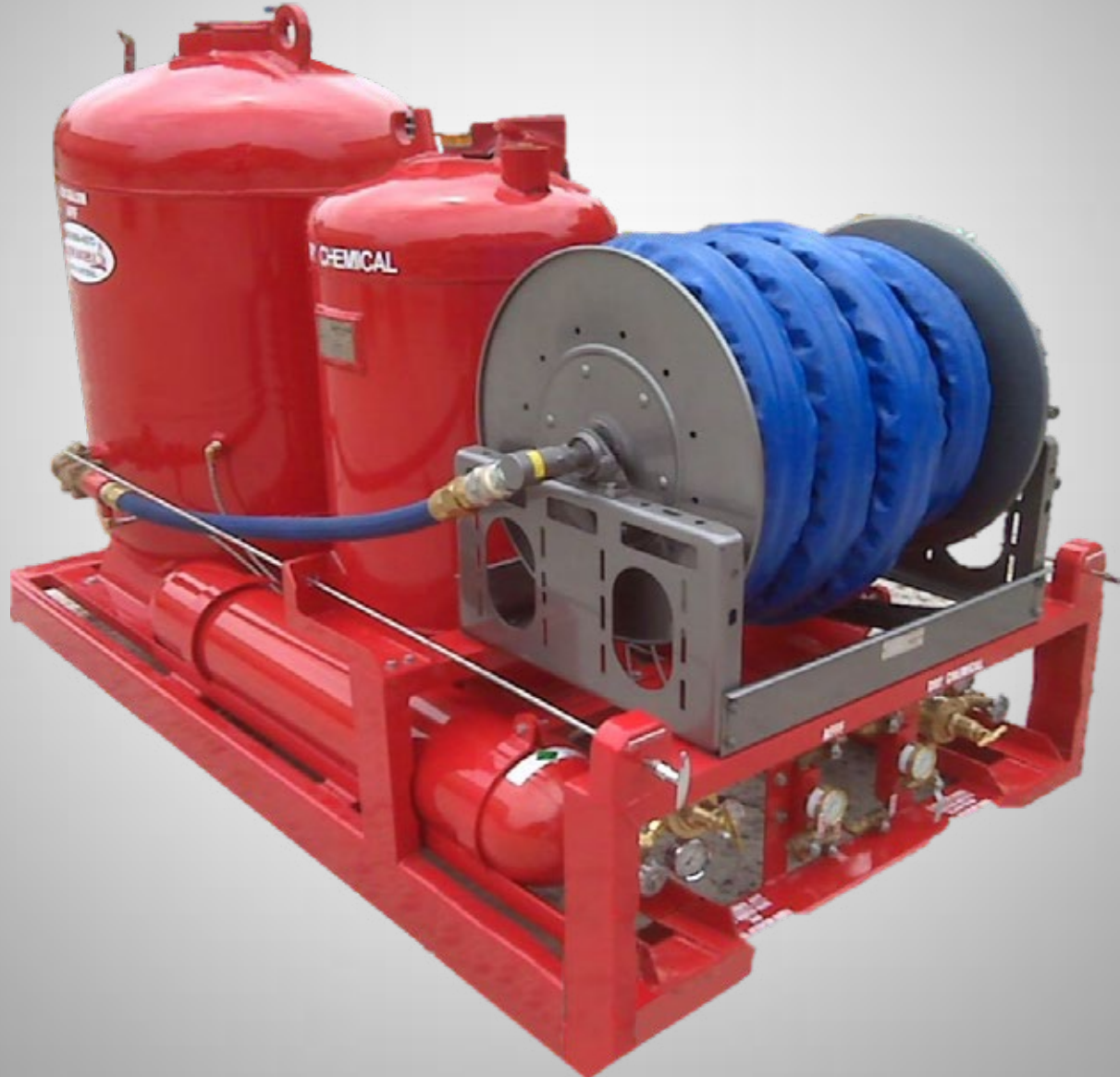

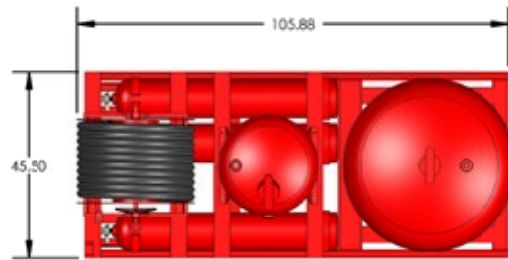

**TOP VIEW**

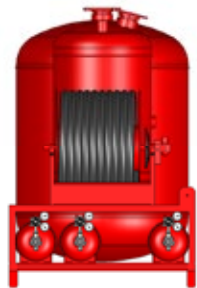

**END VIEW**

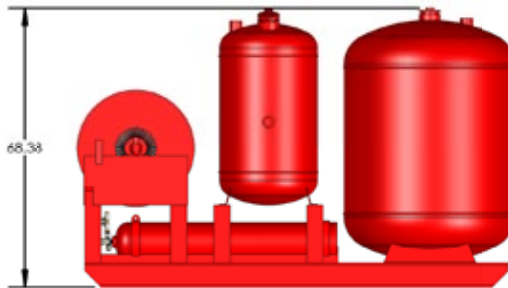

**SIDE VIEW**

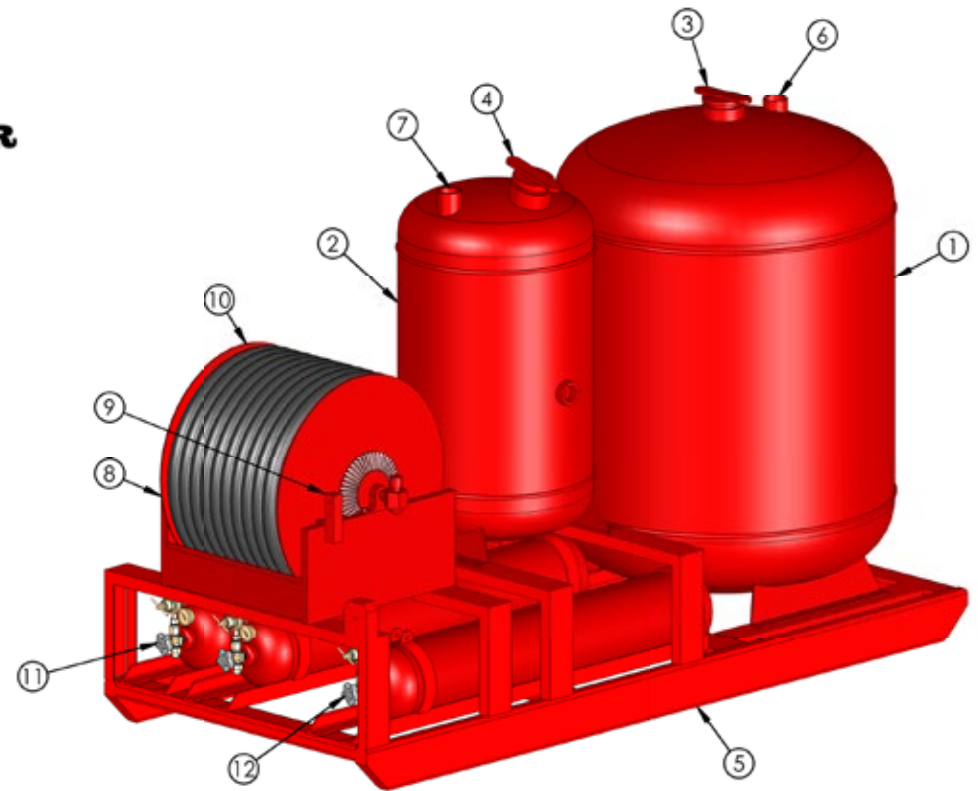

**ISOMETRIC VIEW**

**TWIN AGENT 450 DC 200 AFF**  
**BURNER MODEL AF-450-DC/AFF-200-1HR**

Empty Weight - 2,720 lbs.

Full Weight - 4,836 lbs.

ITEM No.	UNIT DESCRIPTION
1	200 GALLON ASME CODE CYLINDER AFF
2	450 LB ASME CODE CYLINDER DRY CHEMICAL
3	4" FILLER CAP AFF
4	4" FILLER CAP DRY CHEMICAL
5	SKID ASSEMBLY
6	250 PSI POP-OFF AFF
7	250 PSI POP-OFF DRY CHEMICAL
8	MANIFOLD AFF
9	MANIFOLD DRY CHEMICAL
10	HOSE REEL w/ 100 FT. TWIN 1" HOSES & SHUT OFF
11	NITROGEN CYLINDERS AFF
12	NITROGEN CYLINDER DRY CHEMICAL

# 1000 POUND DRY CHEMICAL 150 AFFF TWIN AGENT UNIT



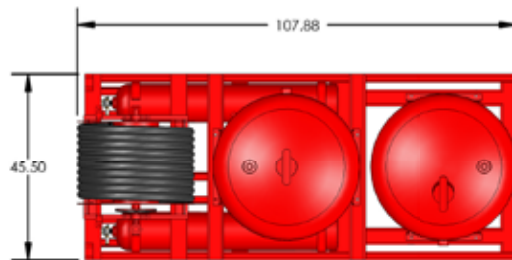

**TOP VIEW**

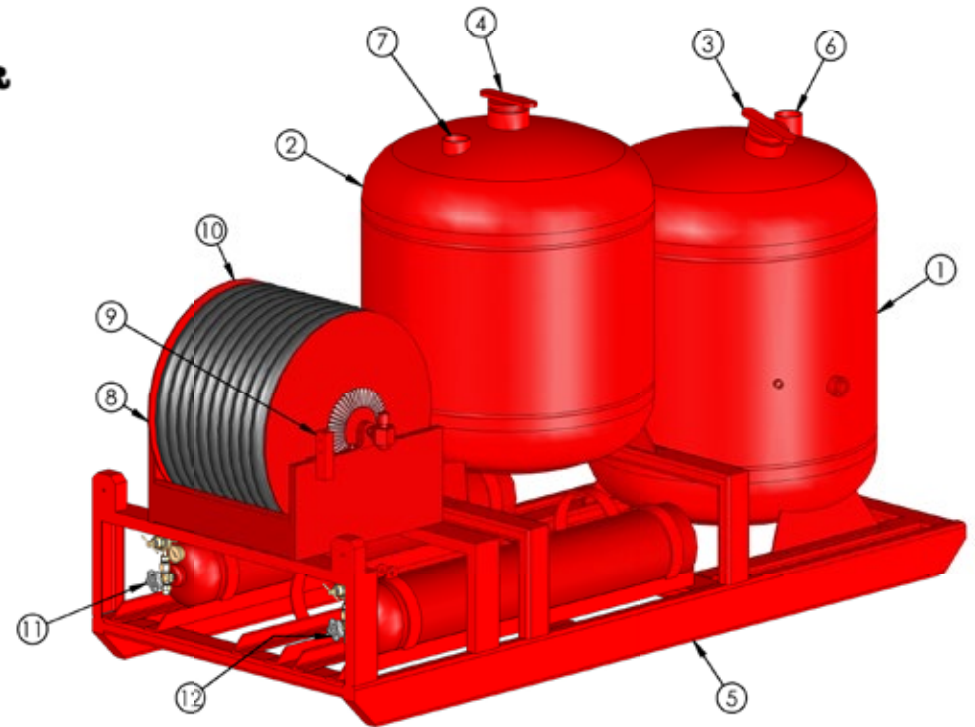

**ISOMETRIC VIEW**



**END VIEW**

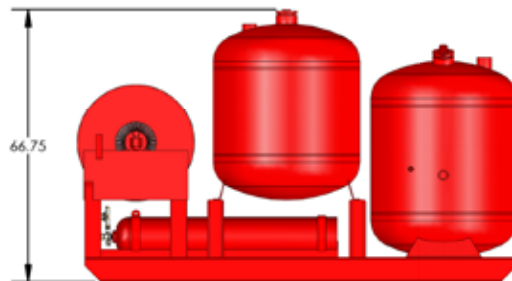

**SIDE VIEW**

**TWIN AGENT 1000 DC 150 AFFF  
BURNER MODEL AF-1000-DC/AFF-150-1HR**

Empty Weight - 3,155 lbs.

Full Weight - 5,405 lbs.

ITEM No.	UNIT DESCRIPTION
1	1.50 GALLON ASME CODE CYLINDER AFFF
2	1000 L3 ASME CODE CYLINDER DRY CHEMICAL
3	4" FILLER CAP AFFF
4	4" FILLER CAP DRY CHEMICAL
5	SKID ASSEMBLY
6	250 PS. POP-OFF AFFF
7	250 PS. POP-OFF DRY CHEMICAL
8	MANIFOLD AFFF
9	MANIFOLD DRY CHEMICAL
10	HOSE REEL w/ 100 FT. TWIN 1" HOSES & SHUT OFF
11	NITROGEN CYLINDER AFFF
12	NITROGEN CYLINDER DRY CHEMICAL

# 3000 POUND DRY CHEMICAL 150 GALLON AFFF TWIN AGENT UNIT



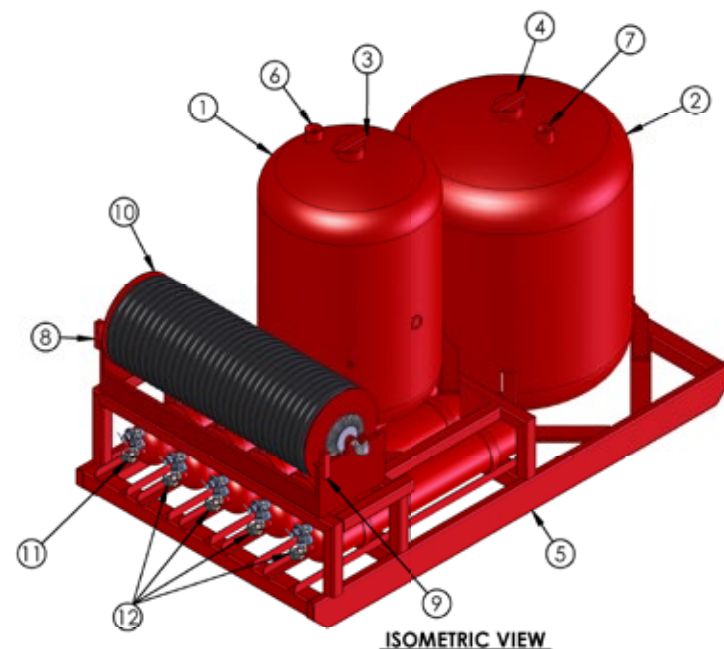
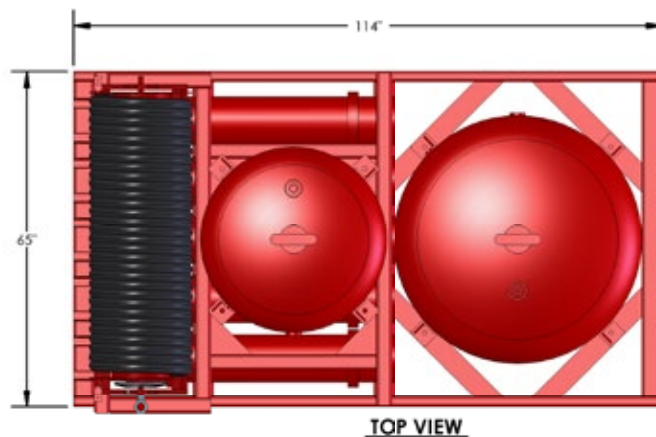

**TWIN AGENT 3000 DC 200 AFFF**

**BURNER MODEL AF-3000-DC/AFFF-200-1HR**

Empty Weight - 4,684 lbs.

Full Weight - 9,350 lbs.

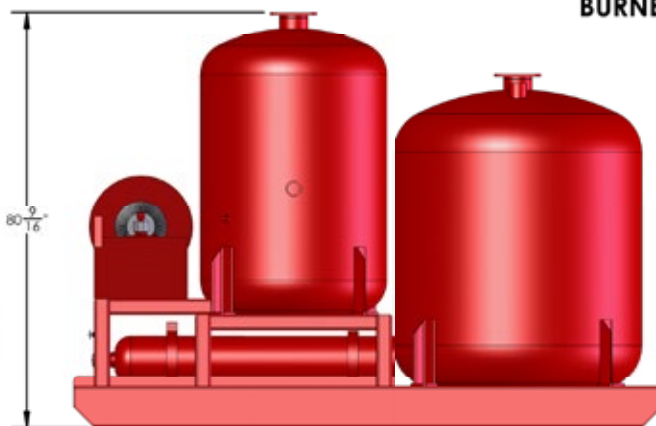

ITEM No.	UNIT DESCRIPTION
1	200 GALLON ASME CODE CYLINDER AFFF
2	3000 LB ASME CODE CYLINDER DRY CHEMICAL
3	4" FILLER CAP AFFF
4	4" FILLER CAP DRY CHEMICAL
5	SKID ASSEMBLY
6	250 PSI POP-OFF AFFF
7	250 PSI POP-OFF DRY CHEMICAL
8	MANIFOLD AFFF
9	MANIFOLD DRY CHEMICAL
10	HOSE REEL w/ 100 FT. TWIN 1" HOSES & SHUT OFF
11	NITROGEN CYLINDER AFFF
12	NITROGEN CYLINDERS DRY CHEMICAL



# **PRE-MIXED FOAM STATIONS**

## **DESCRIPTION**

Burner Pre-Mixed Foam Stations are totally self-contained and require no outside water or power source. These stations address limitations experienced with traditional foam proportioners, around-the-pump systems, foam monitors, applicators, and foam concentrate storage tanks. Units are offered with LOP (Loss of Pressure) actuation system and can be configured for manual or automatic discharge.

## **APPLICATION**

Burner Pre-Mixed Foam Stations provide large capacity rapid response flame attack for Class B fires consisting of flammable liquid spills. The foam acts as a blanket source to smother and cool pooling hydrocarbon liquid while additionally acting as a vapor suppressant to aid in preventing re-ignition of the hazard area. Common high hazard risk areas include:

- Oil Tankers
- Aircraft Hangars
- Fuel Storage Tanks
- Pumping Stations
- Heliports and Helidecks
- Flammable Liquid Storage and Transport
- Fracking Sites

## **COMPONENTS**

Burner Pre-Mixed Foam Stations are self-contained consisting of a carbon steel agent tank assembly designed and constructed in accordance to the latest ASME Section VIII, Div. 1 unfired pressure vessel code. Agent tank is equipped with a 4" fill cap, mechanical pressure safety valve, and internally lined with an epoxy finish. The carrier and expellant agent shall be nitrogen and cylinders shall be of DOT or ISO standard. Nitrogen cylinder storage racks are an integrated part of the station and mounted in vertical position. Complete units are constructed with materials suitable for marine environments. Exterior corrosion resistant coatings applied enables a long lifespan. Complete units are constructed with materials suitable for marine environments. Components are broken down to individual units prior to application of the corrosion resistant paint finish to ensure all surfaces receive the maximum protection possible. Systems are assembled with corrosion resistant hardware and fittings. Skid Welding shall be in accordance with AWS D.1.1 Structural Welding Code, Latest Edition.

# **AFFF SPECIFICATIONS**

<b><u>MODEL</u></b>	<b><u>AF-AFFF-150</u></b>	<b><u>AF-AFFF-150-1HR</u></b>	<b><u>AF-AFFF-300</u></b>	<b><u>AF-AFFF-300-1HR</u></b>	<b><u>AF-AFFF-500</u></b>
<b>CAPACITY</b>	<b>150</b>	<b>150</b>	<b>300</b>	<b>300</b>	<b>500</b>
WEIGHT (LB.)	1194	1450	1894	2150	3260
DEPTH (IN.)	43	43	54	54	62
WIDTH (IN.)	28.313	49	37	58	48
HEIGHT (IN.)	77	77	86.5	86.5	106.5
DISCHARGE RANGE IN (FT.)	50/70	50/70	50/70	50/70	50/70
ASME VESSEL DESIGN INFORMATION	MAWP 250 PSI @450F, MDMT -20F @ 250 PSI	MAWP 250 PSI @450F, MDMT -20F @ 250 PSI	MAWP 250 PSI @450F, MDMT -20F @ 250 PSI	MAWP 250 PSI @450F, MDMT -20F @ 250 PSI	MAWP 250 PSI @450F, MDMT -20F @ 250 PSI
TEMP (F)	+32 to 120°	+32 to 120°	+32 to 120°	+32 to 120°	+32 to 120°
HOSE LENGTH	OPTIONAL	100	OPTIONAL	100	OPTIONAL
REELS	OPTIONAL	1	OPTIONAL	1	OPTIONAL
DIAMETER	2	2	2	2	2
OUTLETS	1	1	2	1	2
RATE (GPM)	60	60	120	60	120
CYLINDER	(1) 300 CF	(1) 300 CF	(2) 300 CF	(1) 300 CF	(4) 300 CF
RELIEF	250 PSI	250 PSI	250 PSI	250 PSI	250 PSI
FILL OPENING (IN.)	4.5" VENTED W/ O-RING	4.5" VENTED W/ O-RING	4.5" VENTED W/ O-RING	4.5" VENTED W/ O-RING	4.5" VENTED W/ O-RING
MATERIAL	Carbon Steel	Carbon Steel	Carbon Steel	Carbon Steel	Carbon Steel
AGENT VESSEL MATERIAL	Carbon Steel	Carbon Steel	Carbon Steel	Carbon Steel	Carbon Steel
AGENT VESSEL THICKNESS (IN.)	3/8"	3/8"	3/8"	3/8"	1/2"
AGENT VESSEL CONSTRUCTION	ASME	ASME	ASME	ASME	ASME
AGENT VESSEL LINING	EPOXY	EPOXY	EPOXY	EPOXY	EPOXY



**BURNER**

[WWW.BURNERFIRE.COM](http://WWW.BURNERFIRE.COM)

337-237-4547

**AFFF UNITS**



# 150 GALLON AFFF UNIT



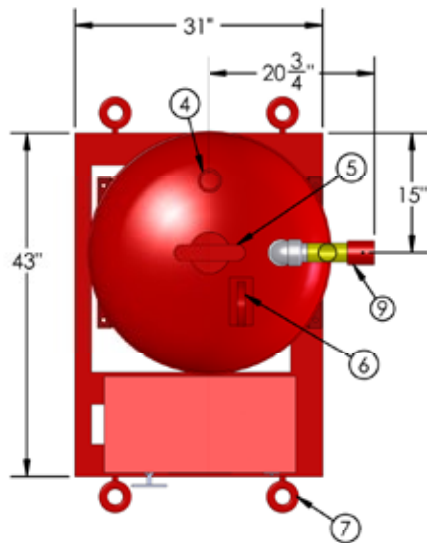

**TOP VIEW**

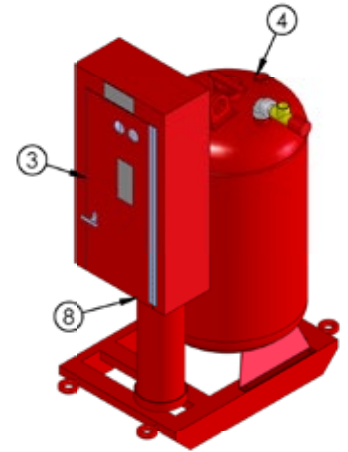

**ISOMETRIC VIEW**

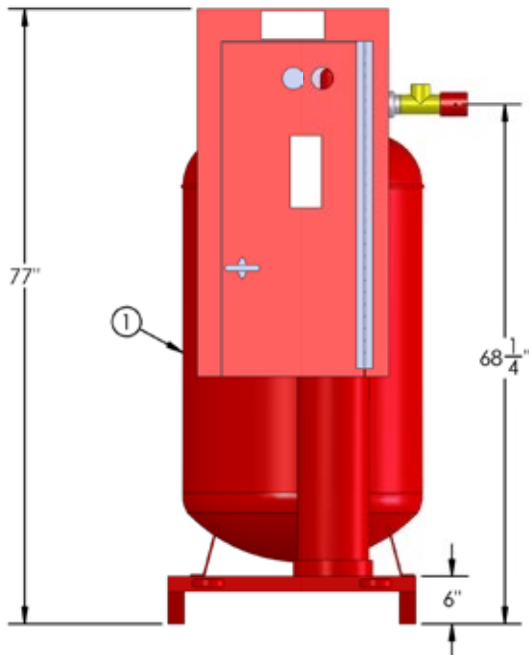

**FRONT VIEW**

**150 GALLON AFF UNIT**  
**BURNER MODEL AF-AFF-150**

EMPTY WEIGHT - 1,194 lbs.

FULL WEIGHT - 2,440 lbs.

ITEM NO.	UNIT DESCRIPTION
1	A.S.M.E. CODE CONTAINER - 30" O.D.
2	UNIT SKID
3	UNIT CABINET
4	SAFETY POP-OFF 250 PSI
5	4" FILLER CAP
6	LIFTING EYELET
7	TOW EYELET
8	300 CU. FT. NITROGEN CYLINDER
9	2" DISCHARGE

# 150 GALLON AFFF UNIT WITH HOSE REEL



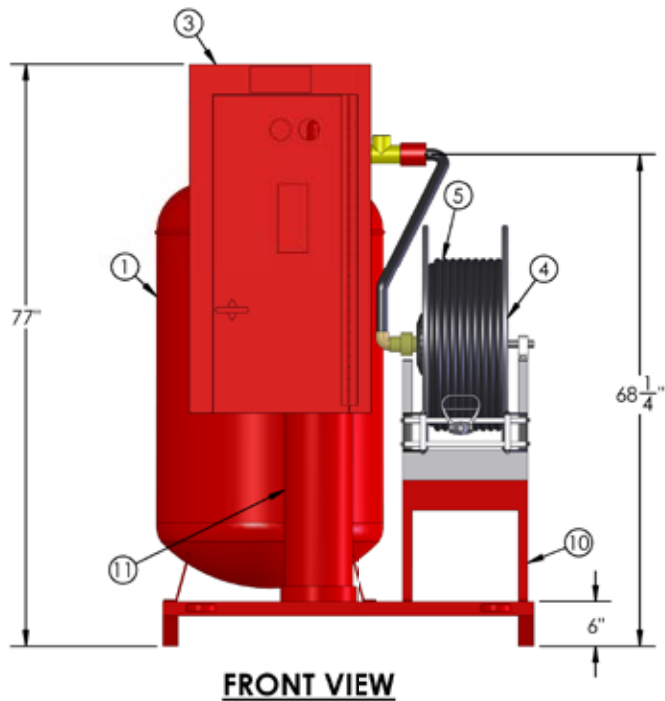
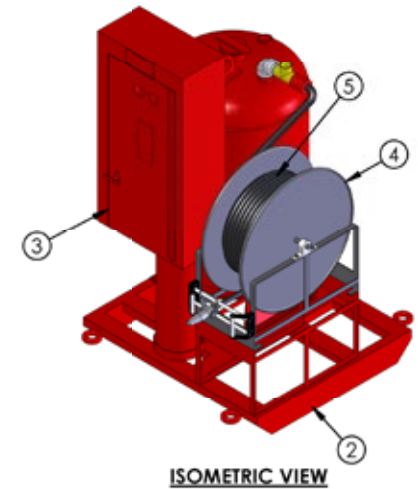
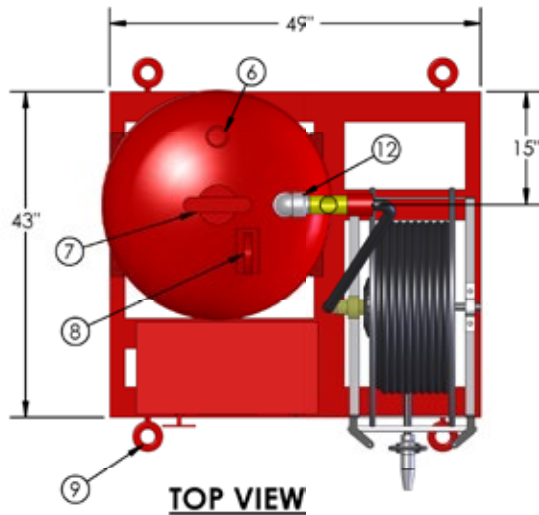

### **150 GALLON AFFF UNIT WITH HOSE REEL**

#### **BURNER MODEL AF-AFF-150-1HR**

EMPTY WEIGHT - 1,450 lbs

FULL WEIGHT - 2,695 lbs

ITEM NO.	UNIT DESCRIPTION
1	A.S.M.E. CODE CONTAINER - 30" O.D.
2	UNIT SKID
3	UNIT CABINET
4	HOSE REEL ASSEMBLY
5	100 FT. SECTION 1" I.D. HOSE WITH SHUTOFF & TIP
6	SAFETY POP-CFF 250 PSI
7	4" FILLER CAP
8	LIFTING EYELET
9	TOW EYELET
10	ELEVATED HOSE REEL STAND
11	300 CU. FT. NITROGEN CYLINDER
12	2" DISCHARGE

# 300 GALLON AFFF UNIT



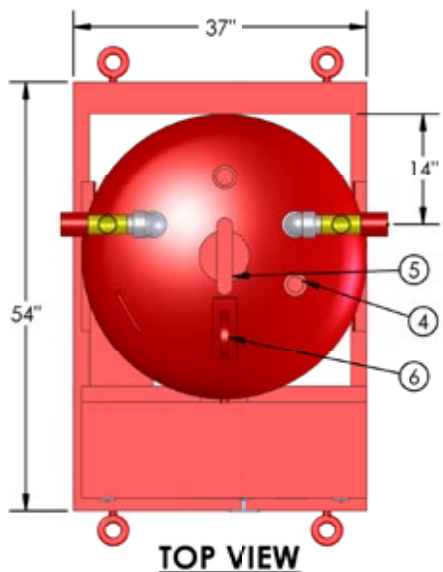

**TOP VIEW**

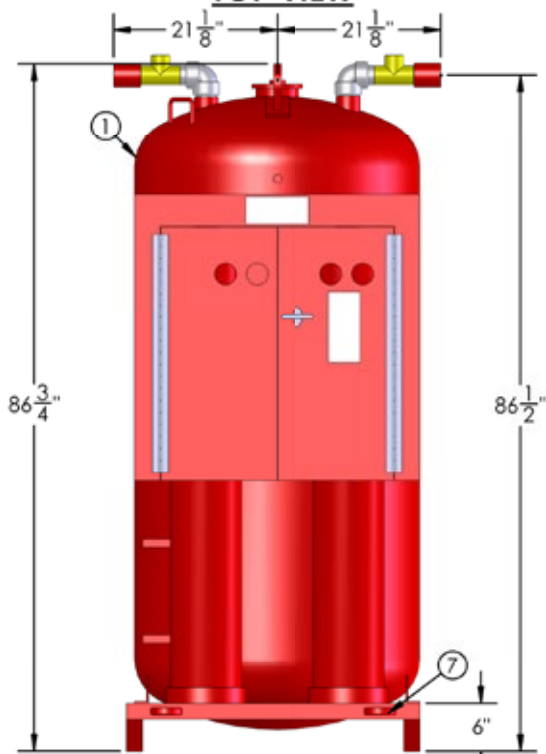

**FRONT VIEW**

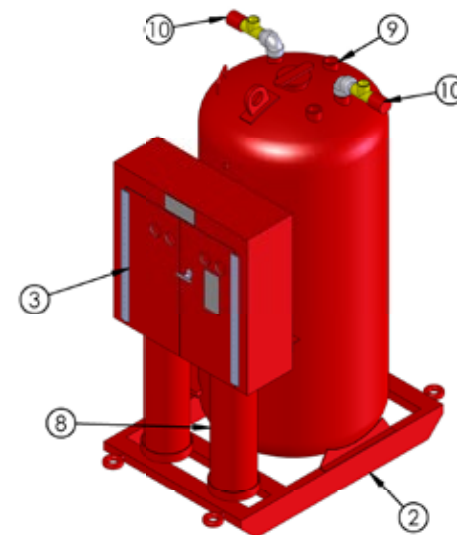

**ISOMETRIC VIEW**

**300 GALLON AFFF UNIT**  
**BURNER MODEL AF-AFF-300**

EMPTY WEIGHT - 1,894 lbs

FULL WEIGHT - 4,393 lbs

ITEM NO.	UNIT DESCRIPTION
1	A.S.M.E. CODE CONTAINER - 36" O.D.
2	UNIT SKID
3	UNIT CABINET
4	SAFETY POP-OFF 250 PSI
5	4" FILLER CAP
6	LIFTING EYELET
7	TOW EYELET
8	300 CU. FT. NITROGEN CYLINDER
9	3" DISCHARGE - OPTIONAL
10	2" DISCHARGE

# 300 GALLON AFFF UNIT WITH HOSE REEL



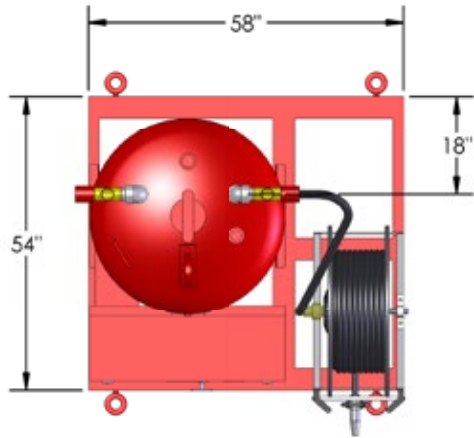

**TOP VIEW**

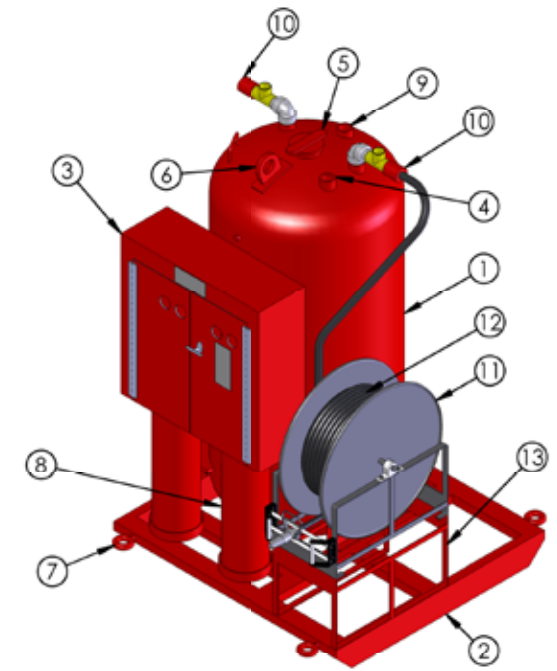

**ISOMETRIC VIEW**

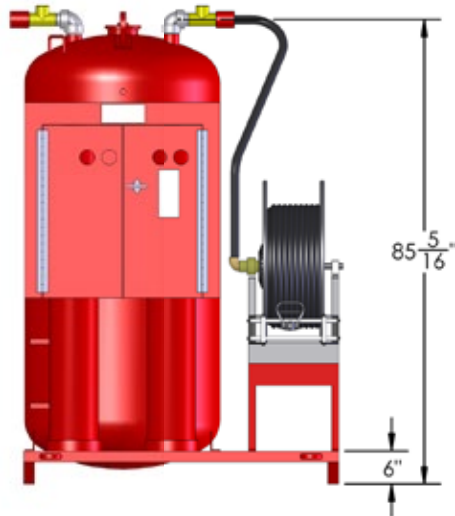

**FRONT VIEW**

**300 GALLON AFFF UNIT WITH HOSE REEL**

**BURNER MODEL AF-AFFF-300-1HR**

EMPTY WEIGHT - 2,150 lbs

FULL WEIGHT - 4,649 lbs

ITEM NO.	UNIT DESCRIPTION
1	A.S.M.E. CODE CONTAINER - 36" O.D.
2	UNIT SKID
3	UNIT CABINET
4	SAFETY POP-OFF 250 PSI
5	4" FILLER CAP
6	LIFTING EYELET
7	TOW EYELET
8	300 CU. FT. NITROGEN CYLINDER
9	3" DISCHARGE - OPTIONAL
10	2" DISCHARGE
11	HOSE REEL ASSEMBLY
12	100 FT. SECTION 1" I.D. HOSE WITH SHUTOFF & TIP
13	ELEVATED HOSE REEL STAND

# 500 GALLON AFFF UNIT



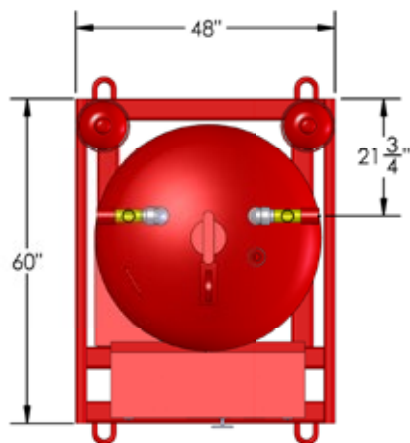

**TOP VIEW**

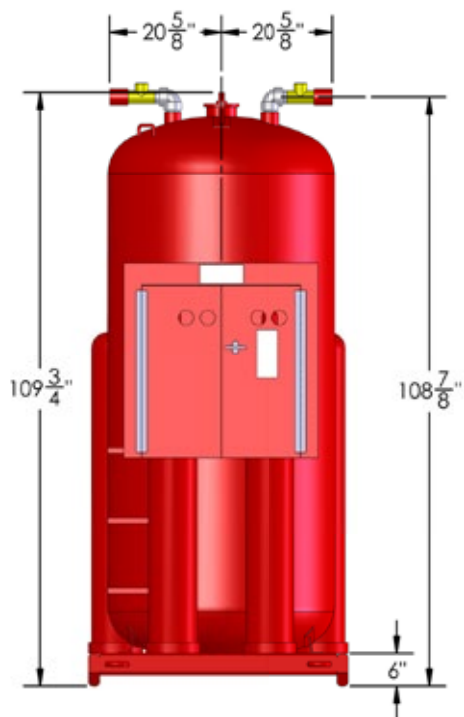

**FRONT VIEW**

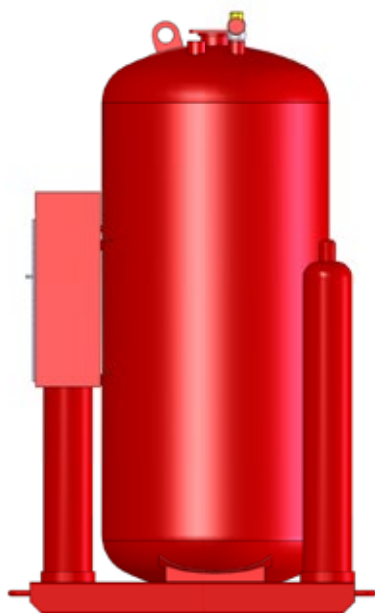

**SIDE VIEW**

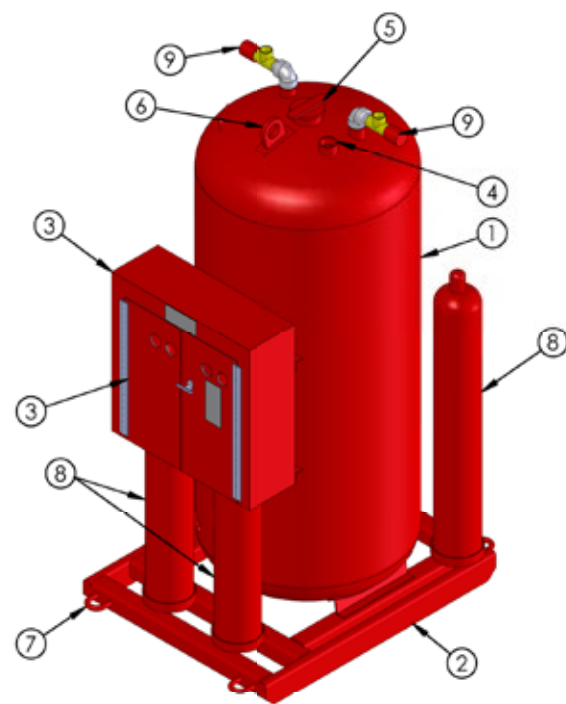

**ISOMETRIC VIEW**

**500 GALLON AFFF UNIT**  
**BURNER MODEL AF-AFFF-500**

EMPTY WEIGHT - 3,260 lbs

FULL WEIGHT - 7,425 lbs

ITEM NO.	UNIT DESCRIPTION
1	A.S.M.E CODE CONTAINER - 42" O.D.
2	UNIT SKID
3	UNIT CABINET
4	SAFETY POP-OFF 250 PSI
5	4" FILLER CAP
6	LIFTING EYELET
7	TOW EYELET
8	300 CU. FT. NITROGEN CYLINDER
9	2" DISCHARGE

**Compressed Air Foam**

# **COMPRESSED AIR FOAM SKID UNITS**

## **DESCRIPTION**

Burner Compressed Air Foam Skid Units are designed for single-person operation and rapid response affording the availability of high expansion foam for maximum fire fighting power in a versatile compact delivery unit. Compressed Air Foam Units are self-contained and stored-energy having the added ability to inject compressed air into the foam solution generating a powerful fire attacking and suppression solution. This foam has an exponentially more dense bubble structure than water and standard foam solutions. The viscosity allows the foam to adhere to vertical and horizontal surfaces and penetrate fires deeper before the compound is broken down allowing latent water to be more effective. Units can be optionally completed with standard skid, trailer, or vehicle mount of choice.

## **APPLICATION**

Burner Compressed Air Foam Units provide rapid flame attack for Class A and B hazard areas. CAFS attacks all sides of the fire tetrahedron by smothering the fire with a "foam blanket", thus preventing oxygen from combining with fuel. It diminishes the heat by insulating and reflecting radiant heat, thus preventing excess heat to the fire via a foam barrier. The versatility of these systems have been proven by field tested use in multiple applications. Common high hazard risk areas include:

- Oil and Gas Production Facilities
- Heliports and Helidecks
- Flammable Liquid Storage and Transport
- Fracking Sites
- Mining Operations
- Race Tracks
- Aircraft Hangars
- Rapid Response Vehicles
- Industrial and Municipal Fire Departments and Brigades
- Military Fire Teams

## **COMPONENTS**

Burner Compressed Air Foam Units are stored-pressure and self-contained consisting of a carbon steel agent tank assembly equipped with a mechanical pressure safety valve and internally lined with an epoxy finish. The carrier and expellant agent shall be air or nitrogen and cylinders shall be of DOT or ISO standard. Cylinder storage racks are an integrated part of the skid. Complete units are constructed with materials suitable for marine environments. Exterior corrosion resistant coatings applied enables a long lifespan. Complete units are constructed with materials suitable for marine environments. Components are broken down to individual units prior to application of the corrosion resistant paint finish to ensure all surfaces receive the maximum protection possible. Systems are assembled with corrosion resistant hardware and fittings. Skid Welding shall be in accordance with AWS D.1.1 Structural Welding Code, Latest Edition.





**BURNER**

[WWW.BURNERFIRE.COM](http://WWW.BURNERFIRE.COM)

337-237-4547

# CAFS UNITS



# 16 GALLON CAFS UNIT MOUNTED ON A 2 WHEEL DOLLY





**BURNER**

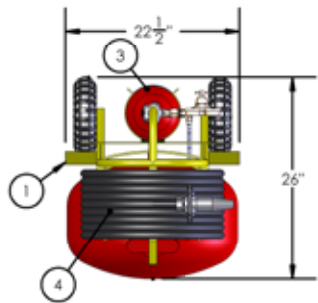

**TOP VIEW**

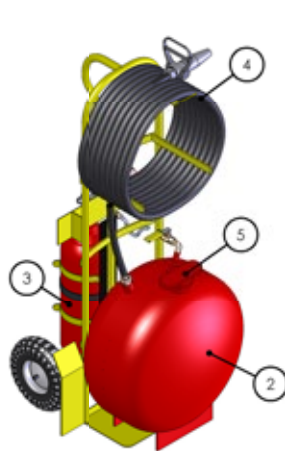

**ISOMETRIC VIEW**

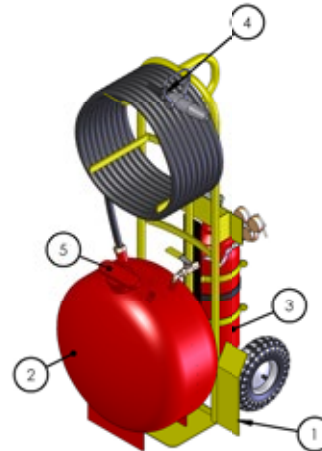

**ISOMETRIC VIEW**

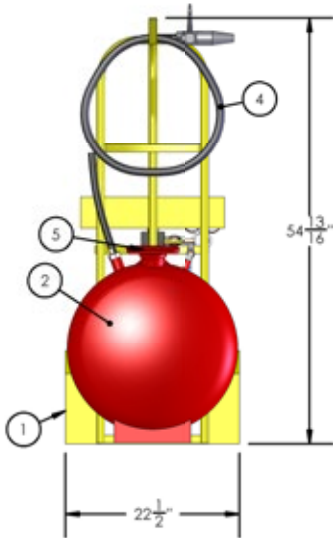

**END VIEW**

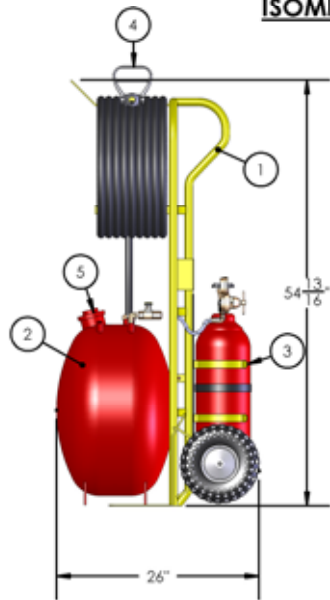

**SIDE VIEW**

**16 GALLON CAFS UNIT**  
**BURNER MODEL CAFS-16-C**

Empty Weight - 208 lbs.

Full Weight - 300 lbs.

ITEM No.	UNIT DESCRIPTION
1	2 WHEEL HEAVY DUTY CART W/ 13" TIRES
2	16 GALLON CAFS VESSEL
3	CAFS 55 CF EXPELLANT BOTTLE
4	HOSE RACK W/ 50FT. 1" HOSE W/ SHUT OFF AND TIP
5	2 1/2" FILL CAP

# 21 GALLON CAFS UNITS



**HORIZONTAL**



**VERTICAL**

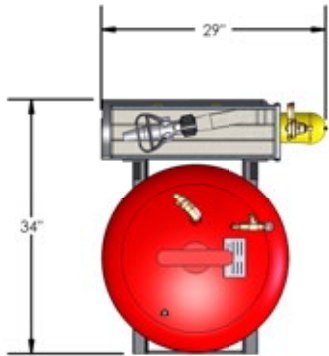

**TOP VIEW**

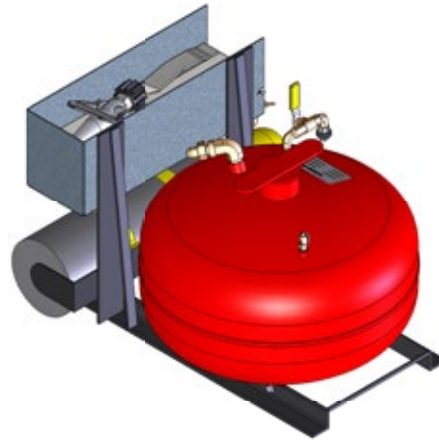

**ISOMETRIC VIEW**

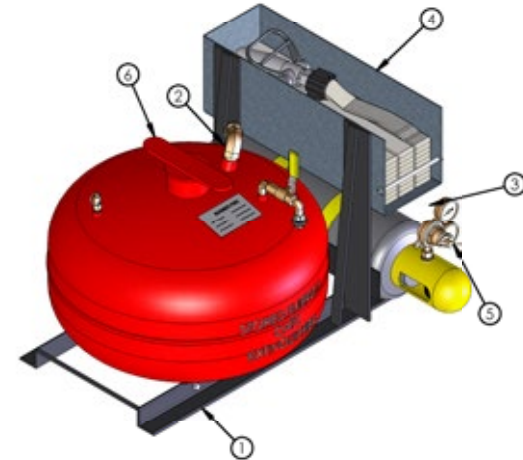

**ISOMETRIC VIEW**

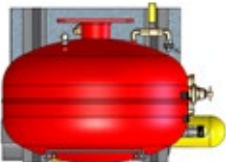

**FRONT VIEW**



**SIDE VIEW**

**21 GALLON HORIZONTAL CAFS UNIT**

**BURNER MODEL CAFS-21-H**

Empty Weight - 168 lbs.

Full Weight - 343 lbs.

ITEM No.	UNIT DESCRIPTION
1	ALUMINUM SKID
2	21 GALLON CAFS VESSEL
3	55 CF EXPELLANT BOTTLE
4	HOSE STORAGE BOX W/ 50 FT. 1" HOSE W/ SHUT OFF AND TIP
5	HARRIS BRASS REGULATOR
6	FILL CAP



**BURNER**

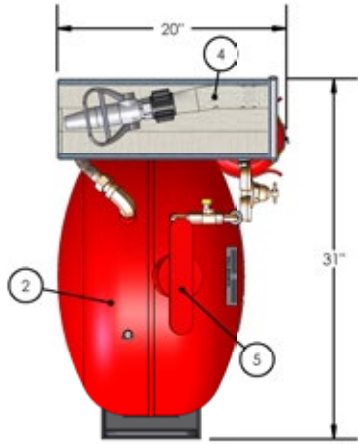

**TOP VIEW**

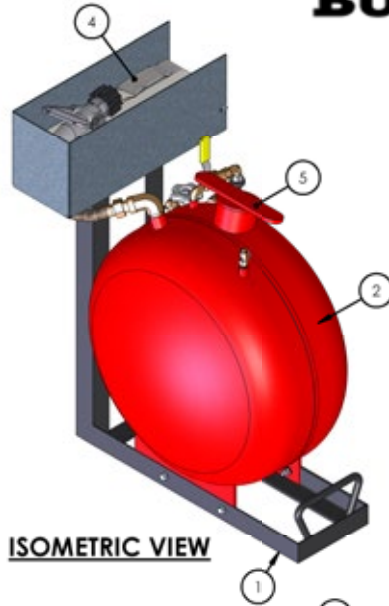

**ISOMETRIC VIEW**

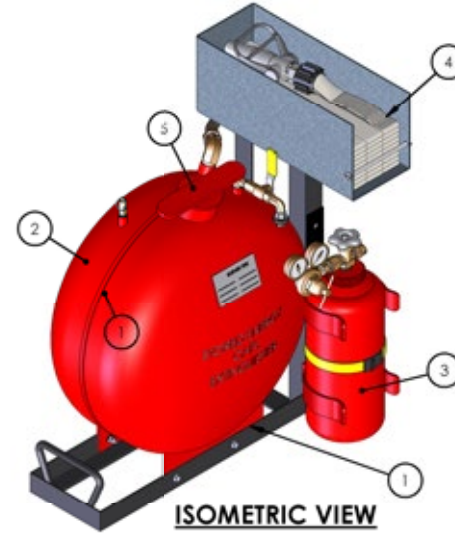

**ISOMETRIC VIEW**

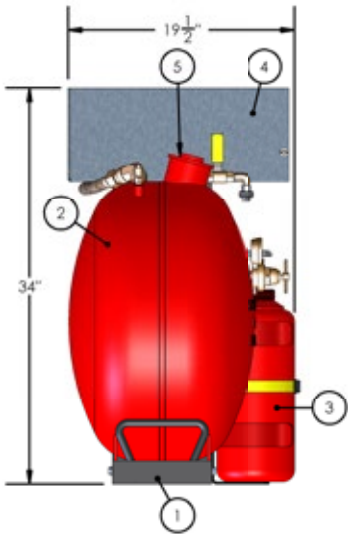

**END VIEW**

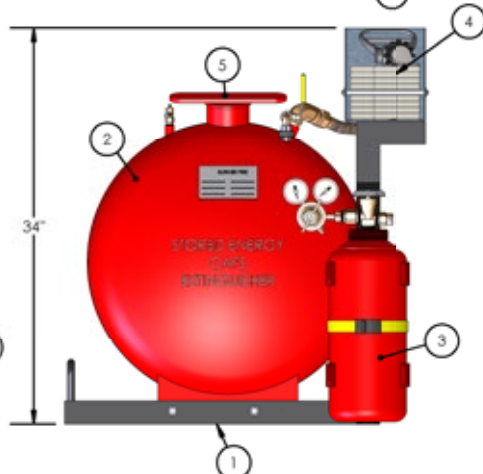

**FRONT VIEW**

**21 GALLON VERTICAL CAFS UNIT**

**BURNER MODEL CAFS-21-V**

Empty Weight - 168 lbs.

Full Weight - 343 lbs.

ITEM No.	UNIT DESCRIPTION
1	ALUMINUM SKID
2	21 GALLON CAFS VESSEL
3	40 CF EXPELLANT BOTTLE
4	HOSE BOX W/ 50FT OF 1" LAY FLAT HOSE W/ SHUT OFF AND TIP.
5	FILL CAP

# 30 GALLON CAFS UNIT MOUNTED ON A 8 WHEEL HEAVY DUTY WAGON TRUCK



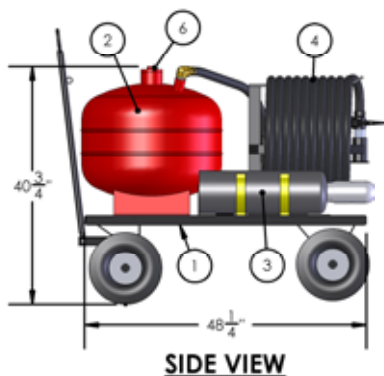
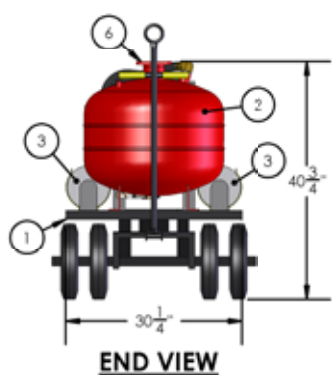
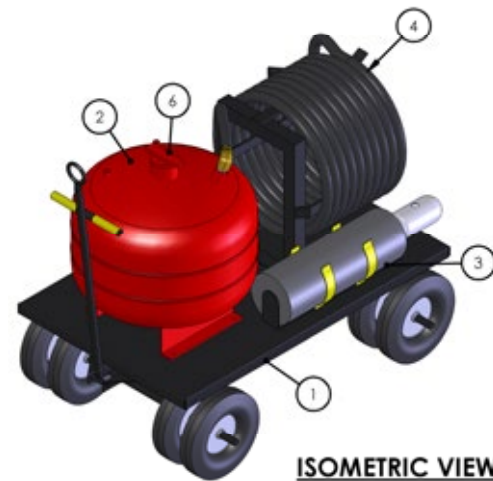
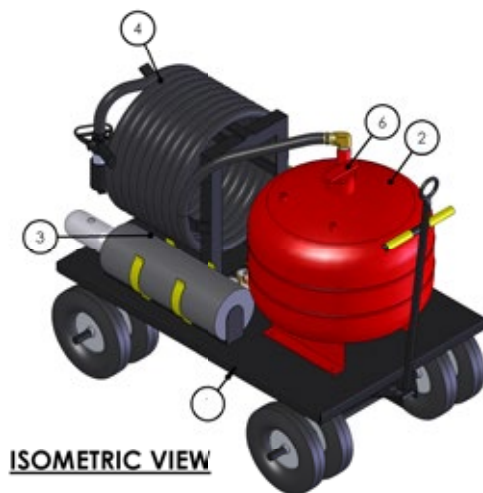
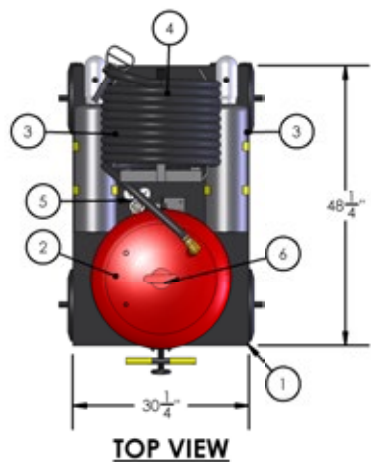

### 30 GALLON 8 WHEELED CART CAFS UNIT

#### **BURNER MODEL CAFS-30-C**

Empty Weight - 386 lbs.

Full Weight - 636 lbs.

ITEM No.	UNIT DESCRIPTION
1	8 WHEELED CART
2	30 GALLON CAFS VESSEL
3	2-55 CF EXPELLANT BOTTLES W/ SAFETY CAPS - ONE SPARE
4	HOSE RACK W/ 50 FT. 1" W/ SHUT OFF AND TIP
5	HARRIS 3500 BRASS REGULATOR
6	FILL CAP

# 30 GALLON CAFS UNIT WITH HOSE REEL





**BURNER**

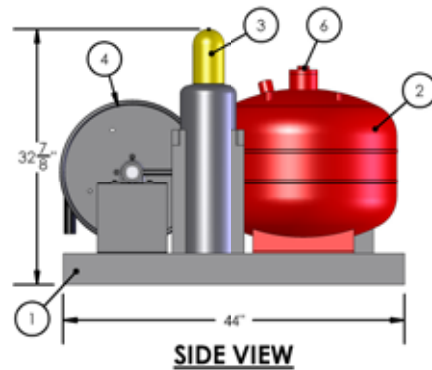
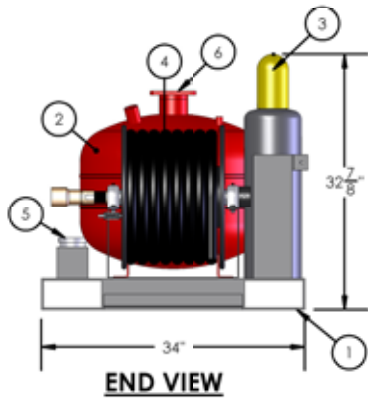
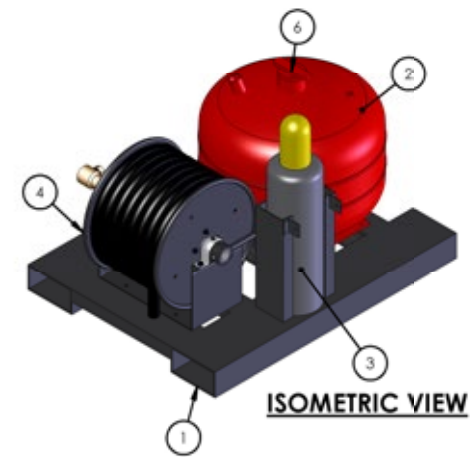
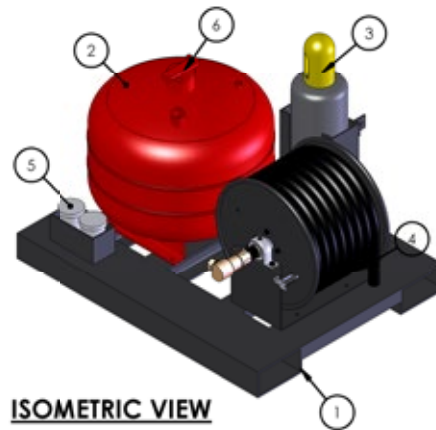
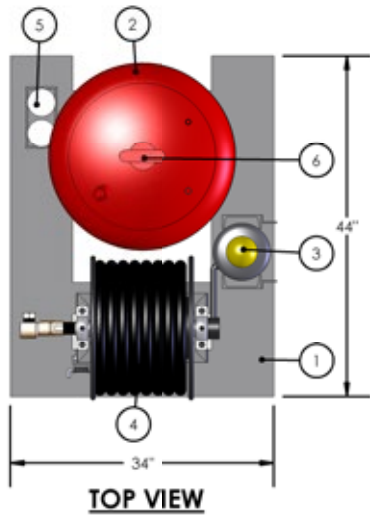

**30 GALLON CAFS UNIT**  
**BURNER MODEL CAFS-30-S**

Empty Weight - 316 lbs.

Full Weight - 566 lbs.

ITEM No.	UNIT DESCRIPTION
1	ALUMINUM SKID W/ COMMERCIAL FORKIFIT CAPABILITIES
2	30 GALLON CAFS VESSEL
3	CAFS 1-55 CF EXPELLANT BOTTLES W/ SAFETY CAP
4	HOSE REEL W/ 50 FT. 1" HOSE
5	(2) ADDITIONAL FOAM CHARGES
6	FILL CAP

# 60 GALLON STANDARD CAFS UNIT



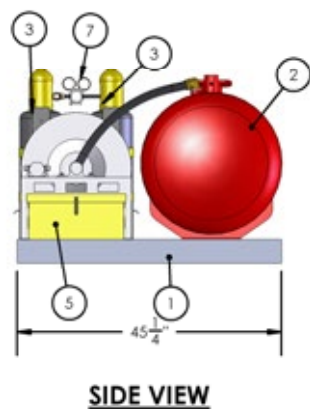
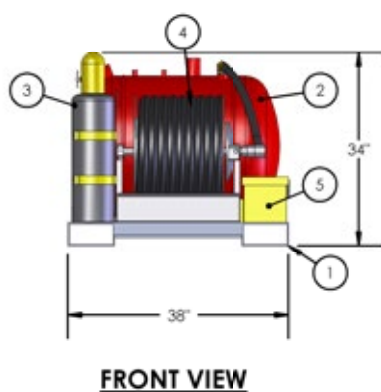
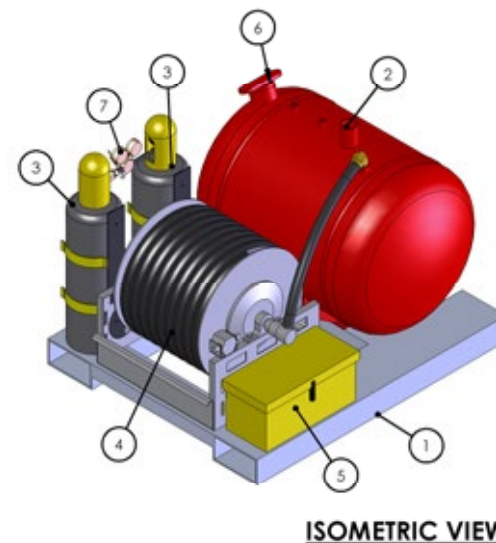
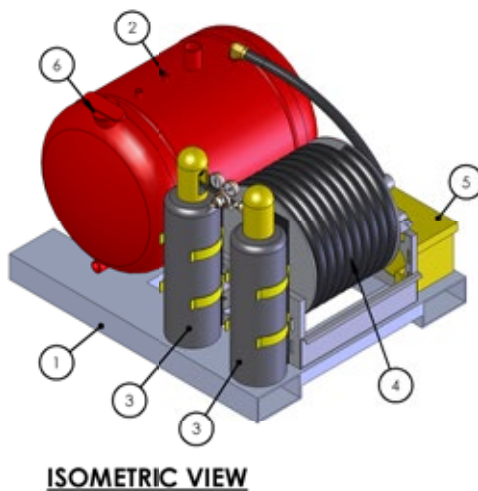
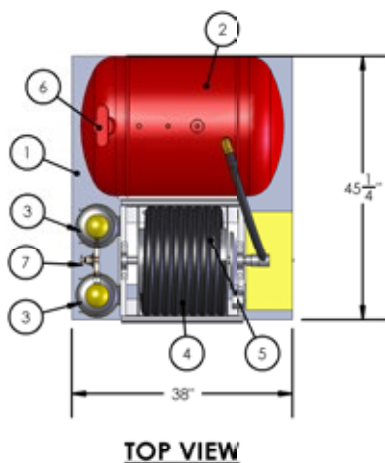

**60 GALLON CAFS UNIT  
BURNER MODEL CAFS-60-S**

Empty Weight - 488 lbs.

Full Weight - 988 lbs.

ITEM No.	UNIT DESCRIPTION
1	ALUMINUM SKID W/ COMMERCIAL FORKFIET CAPABILITIES
2	60 GALLON CAFS VESSEL
3	2-55 CF EXPELLANT BOTTLES
4	HOSE REEL W/ 100 FT. 1" HOSE W/ SHUT OFF AND TIP
5	TOOL BOX
6	FILL CAP
7	HARRIS BRASS REGULATOR

# 60 GALLON MILITARY CAFS UNIT

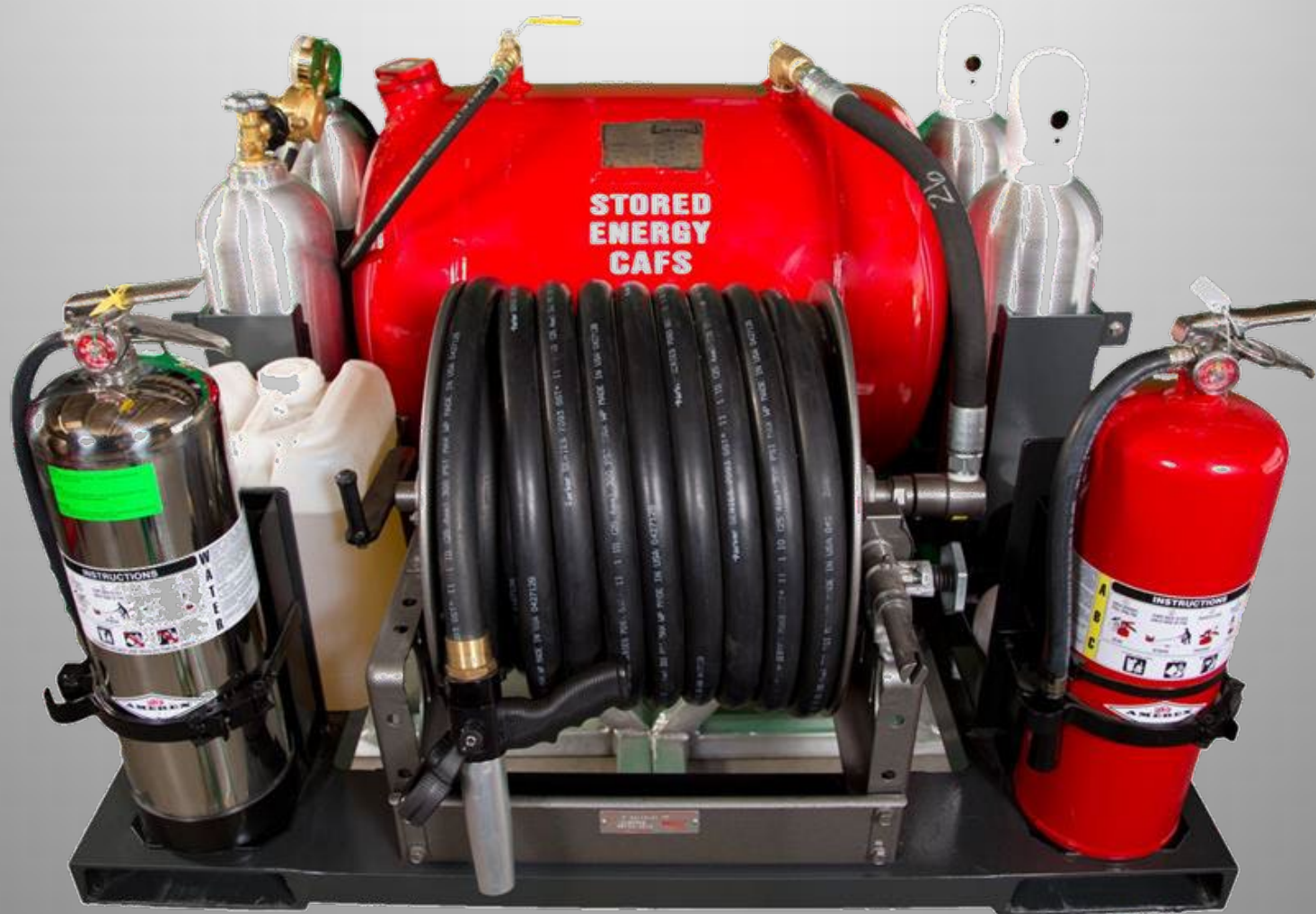



**BURNER**

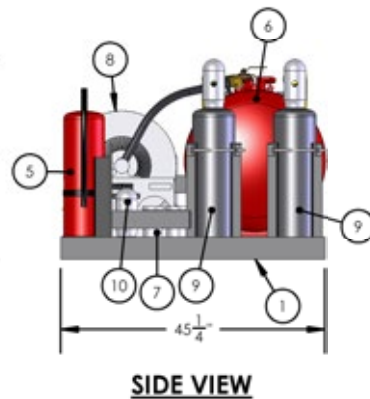
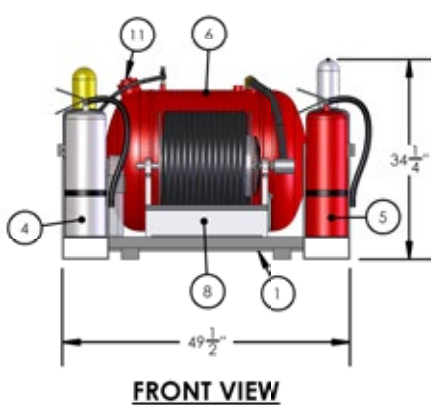
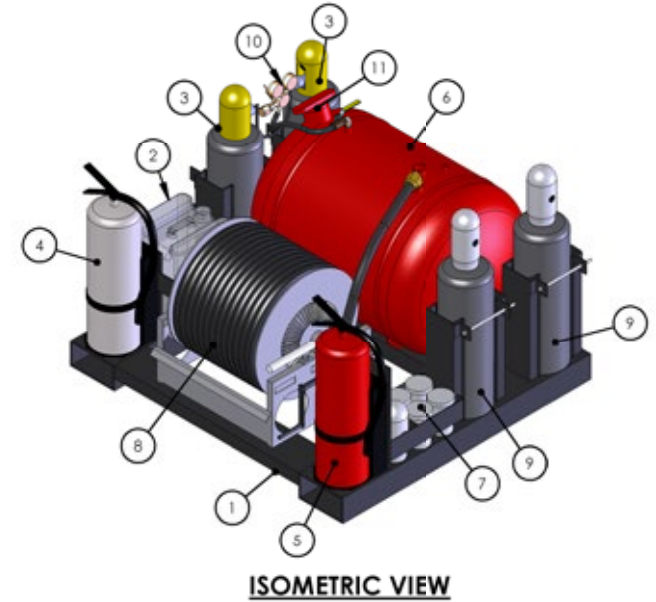
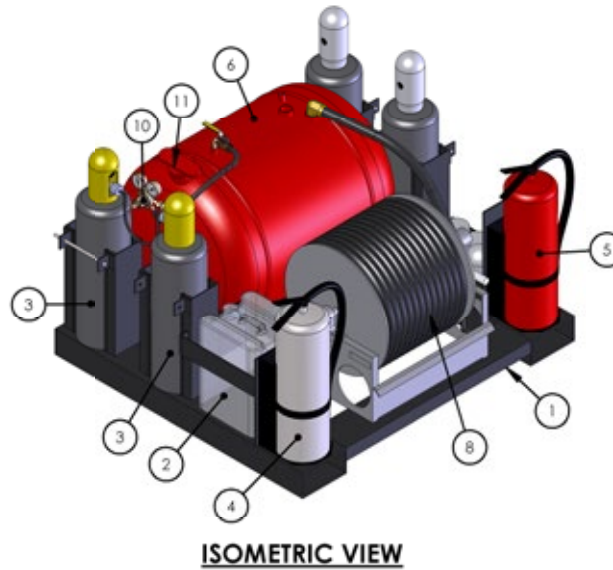
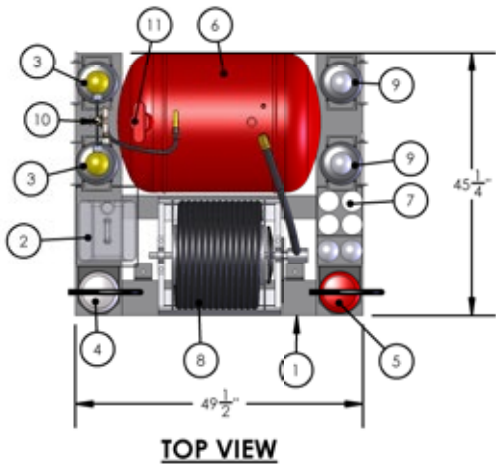

**60 GALLON MILITARY STYLE  
CAFS UNIT**

**BURNER MODEL CAFS-60-M**

Empty Weight - 690 lbs.

Full Weight - 1,190 lbs.

ITEM NO.	UNIT DESCRIPTION
1	ALUMINUM SKID W/ COMMERCIAL FORKLIFT CAPABILITIES
2	5 GALLON FOAM CONTAINER
3	(2) 55 CU.FT. AIR BOTTLE AND REGULATOR WITH SAFETY CAP
4	2 1/2" GALLON WATER FIRE EXTINGUISHER WITH BRACKET
5	20 LBS ABC FIRE EXTINGUISHER WITH BRACKET
6	60 GALLON STORED ENERGY CAFS TANK
7	PRE-MEASURED FOAM CONTAINER - 2 CHARGES
8	HOSE REEL WITH 1" x 100 FT LONG HOSE WITH SHUT OFF AND TIP
9	(2) SPARE 55 CU.FT. BOTTLE
10	HARRIS 3500 BRASS REGULATOR
11	FILL CAP

# 60 GALLON CAFS UNIT WITH 1 1/2" PRE-CONNECT





**BURNER**

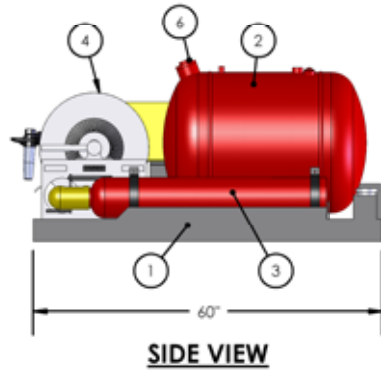
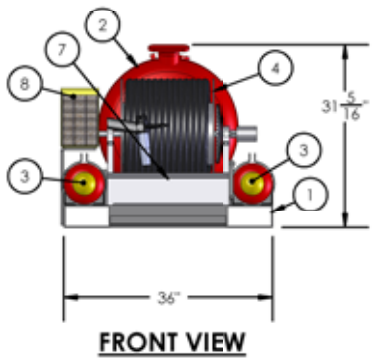
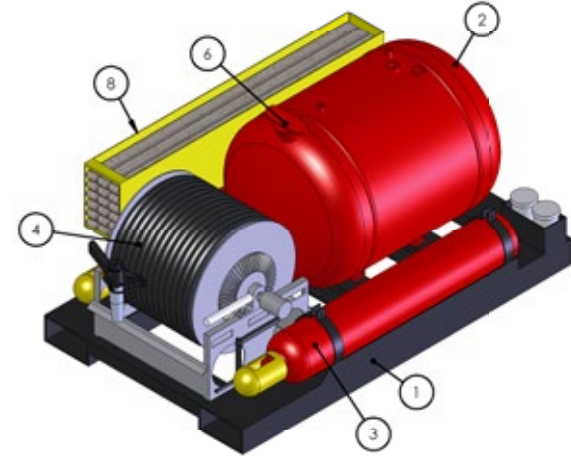
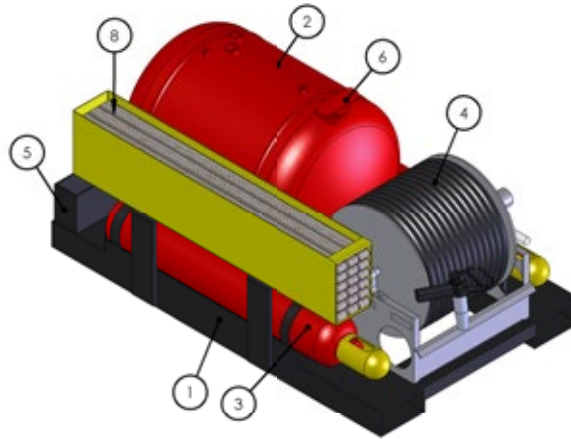
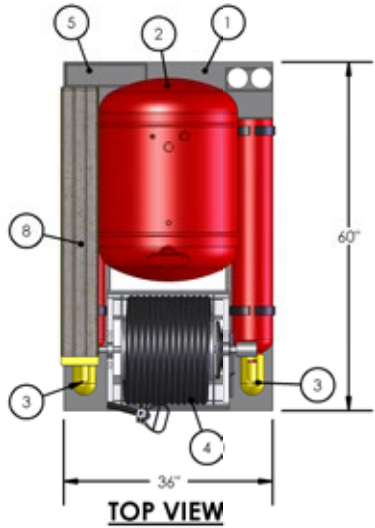

**60 GALLON CAFS UNIT**

**BURNER MODEL CAFS-60-P**

Empty Weight - 700 lbs.

Full Weight - 1,200 lbs.

ITEM No.	UNIT DESCRIPTION
1	ALUMINUM SKID W/ COMMERCIAL FORKFIPT CAPABILITIES
2	60 GALLON CAFS VESSEL
3	2-110 CF EXPELLANT BOTTLES, 150 BAR
4	HOSE REEL W/ 100 FT. - 30M, 1" HOSE W/ SHUT OFF AND TIP
5	TOOL BOX
6	FILL CAP
7	1" DRAIN
8	100 FT. - 1/2" HOSE W/ SHUT OFF AND TIP

# 100 GALLON CAFS UNIT



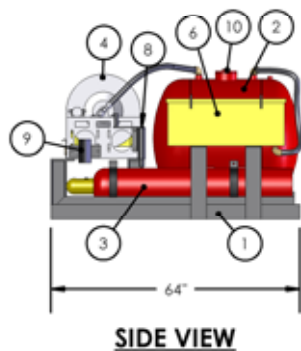
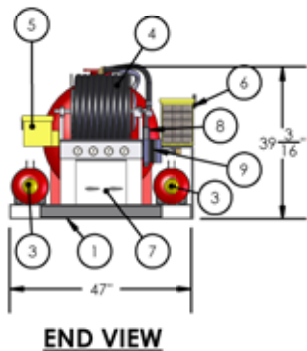
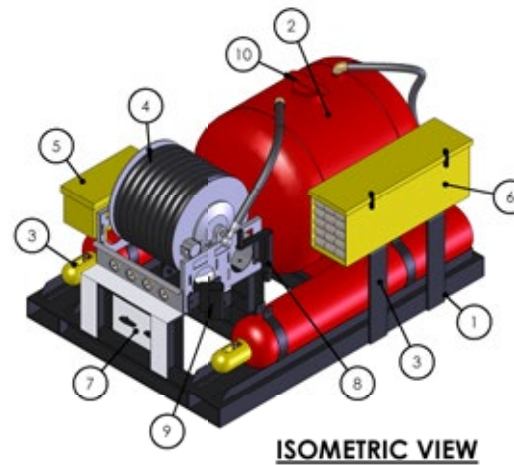
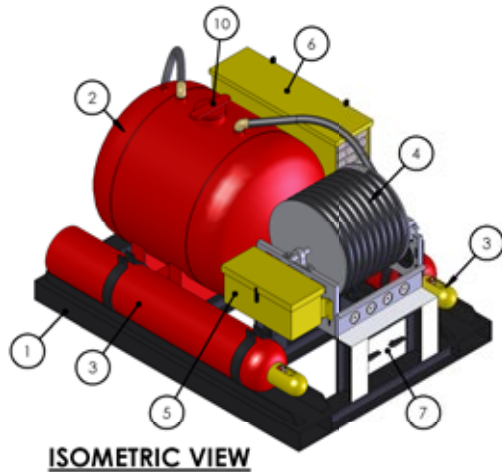
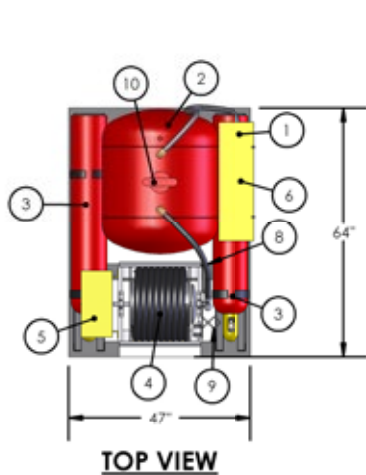

**100 GALLON CAFS UNIT**  
**BURNER MODEL CAFS-100-S**

Empty Weight - 1,026 lbs.

Full Weight - 1,859 lbs.

ITEM No.	UNIT DESCRIPTION
1	ALUMINUM SKID W/ COMMERCIAL FORKIFIT CAPABILITIES
2	100 GALLON CAFS VESSEL
3	CAFS 2-300 CF EXPELLANT BOTTLE - CNE OPTIONAL
4	HOSE REEL W/ 100 FT. 1" HOSE WITH SHUTOFF & TIP
5	TOOL BOX
6	HOSE STORAGE BOX W/ 100 FT 1/2" HOSE W/ SHUTOFF AND TIP - OPTIONAL
7	CONTROL PANEL
8	REEL CRANK
9	SHUTOFF HOLDER
10	FILL CAP

# 200 GALLON CAFS UNIT





**BURNER**

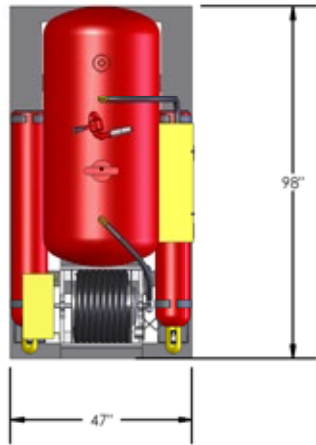

**TOP VIEW**

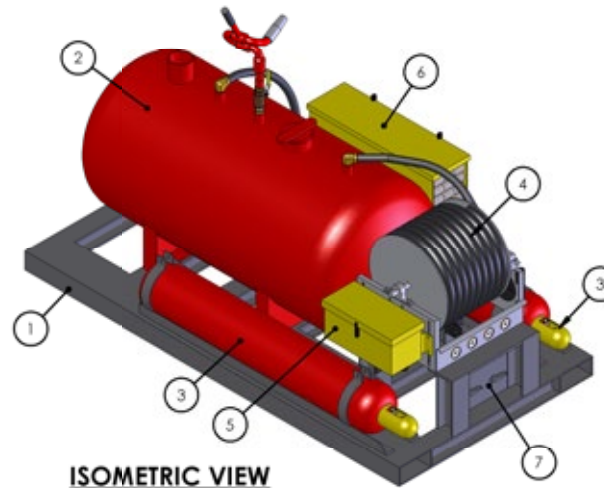

**ISOMETRIC VIEW**

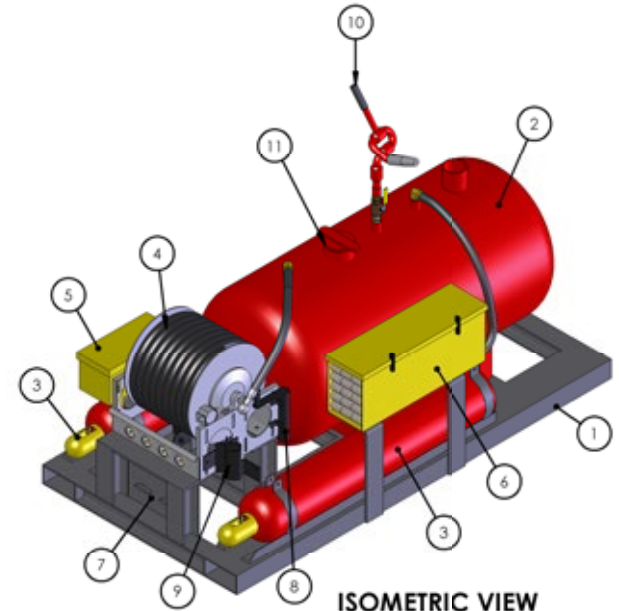

**ISOMETRIC VIEW**

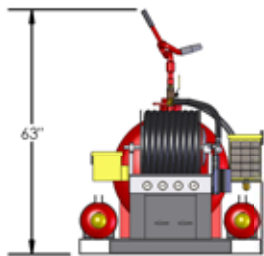

**END VIEW**

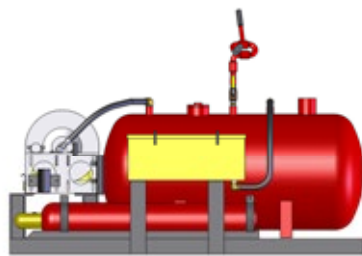

**SIDE VIEW**

**200 GALLON CAFS UNIT  
BURNER MODEL CAFS-200-S**

Empty Weight - 1,386 lbs.

Full Weight - 3,052 lbs.

ITEM No.	UNIT DESCRIPTION
1	ALUMINUM SKID W/ COMMERCIAL FORKFIIT CAPABILITIES
2	200 GALLON CAFS VESSEL
3	(2) 300 CF EXPELLANT BOTTLES
4	HOSE REEL W/ 100 FT. 1" HOSE W/ SHUT OFF TIP.
5	TOOL BOX
6	HOSE STORAGE BOX W/ 100 FT 1 1/2" HOSE W/ SHUTOFF AND TIP
7	CONTROL PANEL
8	REEL CRANK HOLDER
9	SHUTOFF HOLDER
10	DECK GUN - OPTIONAL
11	FILL CAP





**BURNER**

[www.burnerfire.com](http://www.burnerfire.com)

337-237-4547

# CUSTOM UNITS



# 60 GALLON CAFS UNIT



# 60 GALLON CAFS UNIT



# 60 GALLON CAFS UNIT



# 100 GALLON CAFS UNIT



# 60 GALLON CAFS UNIT



# 60 GALLON CAFS UNIT



# 60 GALLON CAFS UNIT



# 30 GALLON CAFS UNIT





# 30 GALLON CAFS UNIT

# 60 GALLON CAFS UNIT



# 70 GALLON CAFS UNIT



# HOSE REEL FOR 70 GALLON CAFS UNIT



# 60 GALLON CAFS UNIT



# 60 GALLONS CAFS UNIT



# 60 GALLON CAFS UNIT



# 30 GALLON CAFS UNIT WITH 100 FOOT LAY FLAT HOSE

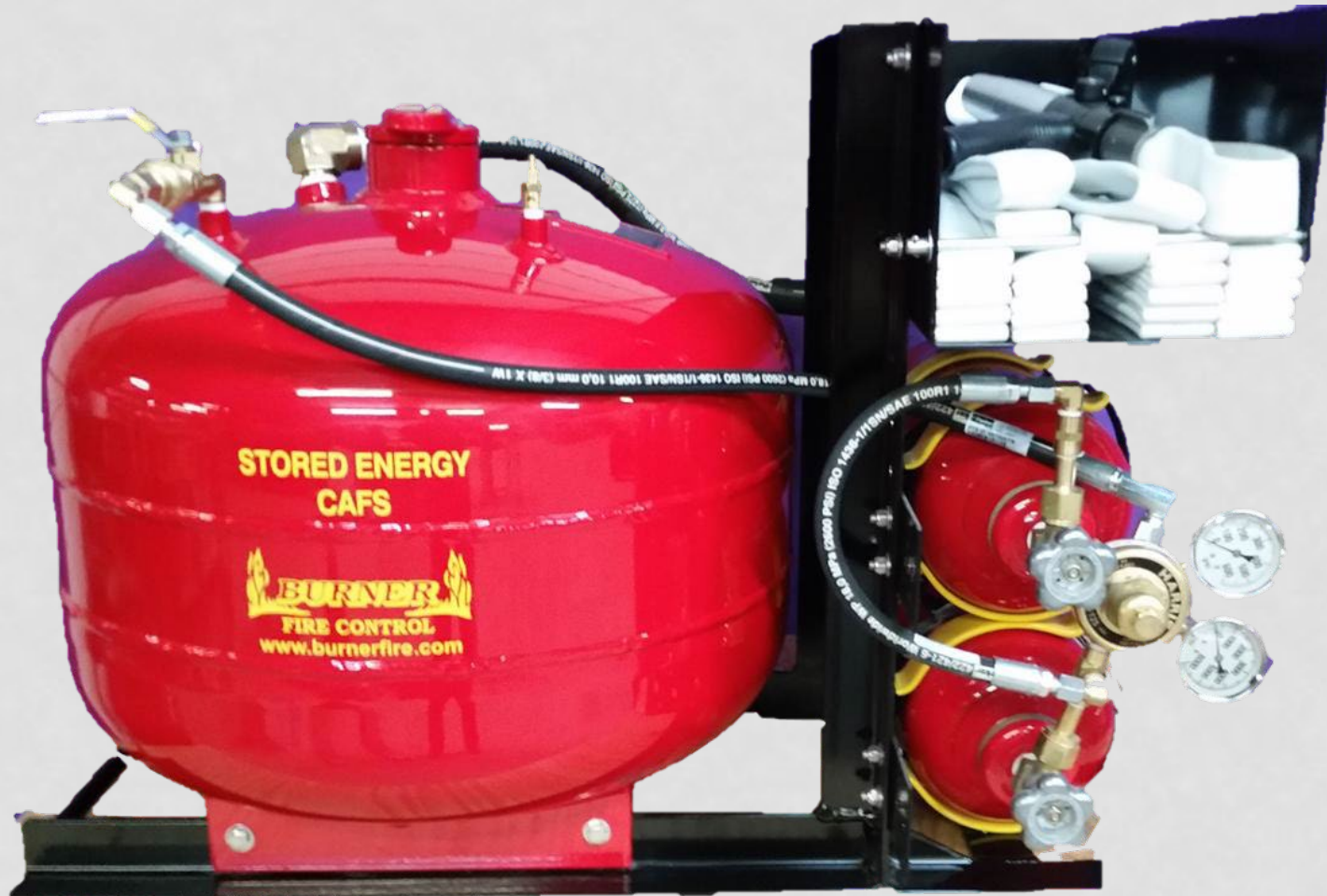

# 1500 POUND DRY CHEMICAL UNIT



# 200 POUND DRY CHEMICAL & 80 GALLONS AFFF TWIN AGENT UNIT



# 450 POUND DRY CHEMICAL & 100 GALLONS AFFF TWIN AGENT UNIT



# 2000 POUND DRY CHEMICAL UNIT



# 1000 POUND DRY CHEMICAL UNIT



# 500 LB DRY CHEMICAL

